



CENTER OF MASS



CENTER OF MASS

Every physical system has associated with it a certain point whose motion characterises the motion of the whole system. When the system moves under some external forces, then this point moves as if the entire mass of the system is concentrated at this point and also the external force is applied at this point for translational motion. This point is called the center of mass of the system.

CENTER OF MASS OF A SYSTEM OF 'N' DISCRETE PARTICLES

Consider a system of N point masses $m_1, m_2, m_3, \dots, m_n$ whose position vectors from origin O are given by $\vec{r}_1, \vec{r}_2, \vec{r}_3, \dots$ respectively. Then the position vector of the center of mass C of the system is given by

$$\vec{r}_{cm} = \frac{m_1\vec{r}_1 + m_2\vec{r}_2 + \dots + m_n\vec{r}_n}{m_1 + m_2 + \dots + m_n}; \quad \vec{r}_{cm} = \frac{\sum_{i=1}^n m_i\vec{r}_i}{\sum_{i=1}^n m_i}$$

$$\vec{r}_{cm} = \frac{1}{M} \sum_{i=1}^n m_i\vec{r}_i$$

where, $m_i\vec{r}_i$ is called the moment of mass of the particle w.r.t O.

$$M = \left(\sum_{i=1}^n m_i \right) \text{ is the total mass of the system.}$$

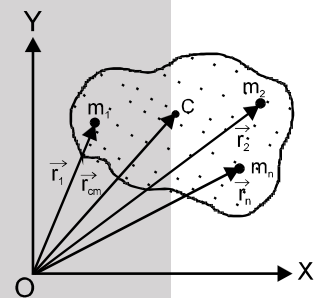

Note: If the origin is taken at the center of mass then $\sum_{i=1}^n m_i\vec{r}_i = 0$. Hence, the COM is the point about which the sum of "mass moments" of the system is zero.

POSITION OF COM OF TWO PARTICLES

Center of mass of two particles of masses m_1 and m_2 separated by a distance r lies in between the two particles. The distance of center of mass from any of the particle (r) is inversely proportional to the mass of the particle (m)

i.e. $r \propto 1/m$

$$\text{or } \frac{r_1}{r_2} = \frac{m_2}{m_1}$$

$$\text{or } m_1r_1 = m_2r_2$$

$$\text{or } r_1 = \left(\frac{m_2}{m_2 + m_1} \right) r \text{ and } r_2 = \left(\frac{m_1}{m_1 + m_2} \right) r$$

Here, r_1 = distance of COM from m_1

and r_2 = distance of COM from m_2

From the above discussion, we see that

$r_1 = r_2 = 1/2$ if $m_1 = m_2$, i.e., COM lies midway between the two particles of equal masses.

Similarly, $r_1 > r_2$ if $m_1 < m_2$ and $r_1 < r_2$ if $m_2 < m_1$, i.e., COM is nearer to the particle having larger mass.

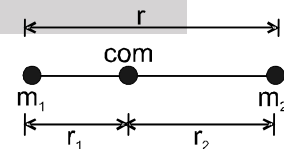



Solved Example

Example 1. Two particles of mass 1 kg and 2 kg are located at $x = 0$ and $x = 3\text{m}$. Find the position of their center of mass.

Solution : Since, both the particles lie on x-axis, the COM will also lie on x-axis. Let the COM is located at $x = x$, then

r_1 = distance of COM from the particle of mass 1 kg = x
and r_2 = distance of COM from the particle of mass 2 kg = $(3 - x)$

$$\text{Using } \frac{r_1}{r_2} = \frac{m_2}{m_1} \quad \text{or} \quad \frac{x}{3-x} = \frac{2}{1} \quad \text{or} \quad x = 2\text{ m}$$

Thus, the COM of the two particles is located at $x = 2\text{m}$

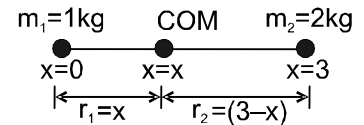

Example 2. The position vector of three particles of masses $m_1 = 1\text{ kg}$, $m_2 = 2\text{ kg}$ and $m_3 = 3\text{ kg}$ are $\vec{r}_1 = (\hat{i} + 4\hat{j} + \hat{k})\text{m}$, $\vec{r}_2 = (\hat{i} + \hat{j} + \hat{k})\text{m}$ and $\vec{r}_3 = (2\hat{i} - \hat{j} - 2\hat{k})\text{m}$ respectively. Find the position vector of their center of mass.

Solution : The position vector of COM of the three particles will be given by $\vec{r}_{\text{COM}} = \frac{m_1\vec{r}_1 + m_2\vec{r}_2 + m_3\vec{r}_3}{m_1 + m_2 + m_3}$

Substituting the values, we get

$$\vec{r}_{\text{COM}} = \frac{(1)(\hat{i} + 4\hat{j} + \hat{k}) + (2)(\hat{i} + \hat{j} + \hat{k}) + (3)(2\hat{i} - \hat{j} - 2\hat{k})}{1 + 2 + 3} = \frac{1}{2}(3\hat{i} + \hat{j} - \hat{k})\text{m}$$

Ans.

Example 3. Four particles of mass 1 kg, 2 kg, 3 kg and 4 kg are placed at the four vertices A, B, C and D of a square of side 1 m. Find the position of center of mass of the particles.

Solution : Assuming D as the origin, DC as x-axis and DA as y-axis, we have

$m_1 = 1\text{ kg}$, $(x_1, y_1) = (0, 1\text{m})$

$m_2 = 2\text{ kg}$, $(x_2, y_2) = (1\text{m}, 1\text{m})$

$m_3 = 3\text{ kg}$, $(x_3, y_3) = (1\text{m}, 0)$

and $m_4 = 4\text{ kg}$, $(x_4, y_4) = (0, 0)$

Co-ordinates of their COM are

$$x_{\text{COM}} = \frac{m_1x_1 + m_2x_2 + m_3x_3 + m_4x_4}{m_1 + m_2 + m_3 + m_4} = \frac{(1)(0) + 2(1) + 3(1) + 4(0)}{1 + 2 + 3 + 4} = \frac{5}{10} = \frac{1}{2}\text{ m} = 0.5\text{ m}$$

$$\text{Similarly, } y_{\text{COM}} = \frac{m_1y_1 + m_2y_2 + m_3y_3 + m_4y_4}{m_1 + m_2 + m_3 + m_4} = \frac{(1)(1) + 2(1) + 3(0) + 4(0)}{1 + 2 + 3 + 4} = \frac{3}{10} = 0.3\text{ m}$$

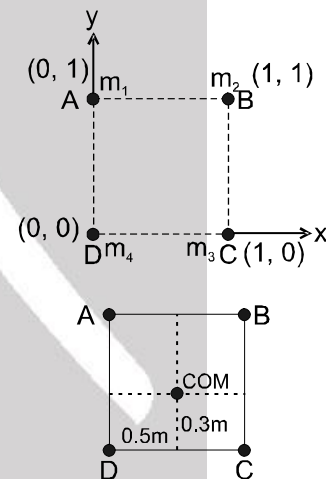

$$\therefore (x_{\text{COM}}, y_{\text{COM}}) = (0.5\text{ m}, 0.3\text{ m})$$

Ans.

Thus, position of COM of the four particles is as shown in figure.

Example 4. Consider a two-particle system with the particles having masses m_1 and m_2 . If the first particle is pushed towards the center of mass through a distance d , by what distance should the second particle be moved so as to keep the center of mass at the same position?

Solution : Consider figure. Suppose the distance of m_1 from the center of mass C is x_1 and that of m_2 from C is x_2 . Suppose the mass m_2 is moved through a distance d' towards C so as to keep the center of mass at C.

$$\text{Then, } m_1x_1 = m_2x_2 \quad \text{.....(i)}$$

$$\text{and } m_1(x_1 - d) = m_2(x_2 - d') \quad \text{.....(ii)}$$

Subtracting (ii) from (i)

$$m_1d = m_2d' \quad \text{or, } d' = \frac{m_1}{m_2}d$$

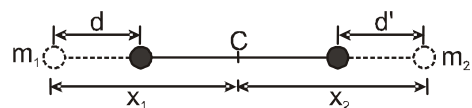



CENTER OF MASS OF A CONTINUOUS MASS DISTRIBUTION

For continuous mass distribution the center of mass can be located by replacing summation sign with an integral sign. Proper limits for the integral are chosen according to the situation

$$x_{cm} = \frac{\int x dm}{\int dm}, \quad y_{cm} = \frac{\int y dm}{\int dm}, \quad z_{cm} = \frac{\int z dm}{\int dm}$$

$$\int dm = M \text{ (mass of the body)}$$

$$\vec{r}_{cm} = \frac{1}{M} \int \vec{r} dm$$

Note: If an object has symmetric mass distribution about x axis then y coordinate of COM is zero and vice-versa

CENTER OF MASS OF A UNIFORM ROD

Suppose a rod of mass M and length L is lying along the x-axis with its one end at $x = 0$ and the other at $x = L$. Mass per unit length of the rod = $\frac{M}{L}$

Hence, dm, (the mass of the element dx situated at $x = x$ is) = $\frac{M}{L} dx$

The coordinates of the element dx are $(x, 0, 0)$. Therefore, x-coordinate of COM of the rod will be

$$x_{COM} = \frac{\int_0^L x dm}{\int dm} = \frac{\int_0^L x \left(\frac{M}{L} dx\right)}{M} = \frac{1}{L} \int_0^L x dx = \frac{L}{2}$$

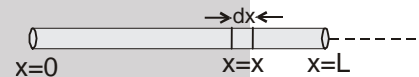

The y-coordinate of COM is $y_{COM} = \frac{\int y dm}{\int dm} = 0$. Similarly, $z_{COM} = 0$

i.e., the coordinates of COM of the rod are $\left(\frac{L}{2}, 0, 0\right)$, i.e. it lies at the center of the rod.

Solved Example

Example 5. A rod of length L is placed along the x-axis between $x = 0$ and $x = L$. The linear density (mass/length) λ of the rod varies with the distance x from the origin as $\lambda = Rx$. Here, R is a positive constant. Find the position of center of mass of this rod.

Solution : Mass of element dx situated at $x = x$ is $dm = \lambda dx = Rx dx$
The COM of the element has coordinates $(x, 0, 0)$
Therefore, x-coordinate of COM of the rod will be x_{COM}

$$x_{COM} = \frac{\int_0^L x dm}{\int_0^L dm} = \frac{\int_0^L x (Rx) dx}{\int_0^L (Rx) dx} = \frac{R \int_0^L x^2 dx}{R \int_0^L x dx} = \frac{\left[\frac{x^3}{3}\right]_0^L}{\left[\frac{x^2}{2}\right]_0^L} = \frac{2L}{3}$$

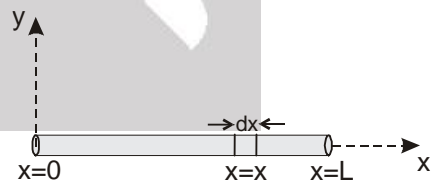

The y-coordinate of COM of the rod is $y_{COM} = \frac{\int y dm}{\int dm} = 0$ (as $y = 0$)

Similarly, $z_{COM} = 0$

Hence, the center of mass of the rod lies at $\left[\frac{2L}{3}, 0, 0\right]$

Ans.



CENTER OF MASS OF A SEMICIRCULAR RING

Figure shows the object (semi circular ring). By observation we can say that the x-coordinate of the center of mass of the ring is zero as the half ring is symmetrical about y-axis on both sides of the origin. Only we are required to find the y-coordinate of the center of mass.

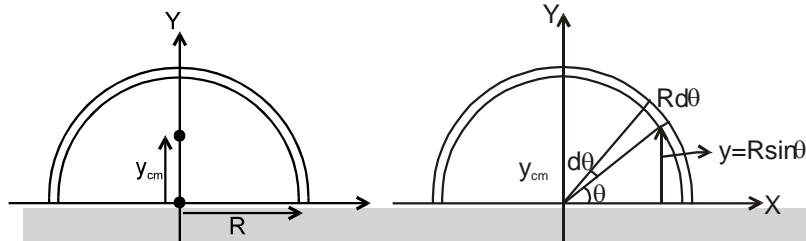

To find y_{cm} we use $y_{cm} = \frac{1}{M} \int dm y$ (i)

Here for dm we consider an elemental arc of the ring at an angle θ from the x-direction of angular width $d\theta$. If radius of the ring is R then its y coordinate will be $R \sin\theta$, here dm is given as

$$dm = \frac{M}{\pi R} \times R d\theta$$

So from equation(i), we have

$$y_{cm} = \frac{1}{M} \int_0^\pi \frac{M}{\pi R} R d\theta (R \sin\theta) = \frac{R}{\pi} \int_0^\pi \sin\theta d\theta$$

$$y_{cm} = \frac{2R}{\pi} \quad \text{.....(ii)}$$

CENTER OF MASS OF SEMICIRCULAR DISC

Figure shows the half disc of mass M and radius R . Here, we are only required to find the y-coordinate of the center of mass of this disc as center of mass will be located on its half vertical diameter. Here to find y_{cm} , we consider a small elemental ring of mass dm of radius x on the disc (disc can be considered to be made up such thin rings of increasing radii) which will be integrated from 0 to R . Here dm is given

$$\text{as } dm = \frac{2M}{\pi R^2} (\pi x) dx$$

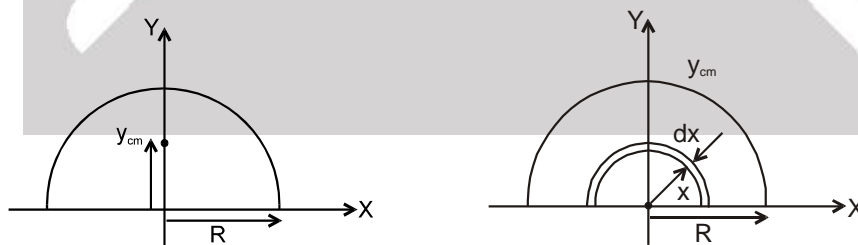

Now the y-coordinate of the element is taken as $\frac{2x}{\pi}$, as in previous section, we have derived that the

center of mass of a semi circular ring is concentrated at $\frac{2R}{\pi}$

$$\text{Here } y_{cm} \text{ is given as } y_{cm} = \frac{1}{M} \int_0^R dm \frac{2x}{\pi} = \frac{1}{M} \int_0^R \frac{4M}{\pi R^2} x^2 dx$$

$$y_{cm} = \frac{4R}{3\pi}$$



CENTER OF MASS OF A SOLID HEMISPHERE

The hemisphere is of mass M and radius R . To find its center of mass (only y -coordinate), we consider an element disc of width dy , mass dm at a distance y from the center of the hemisphere. The radius of this elemental disc will be given as $r = \sqrt{R^2 - y^2}$

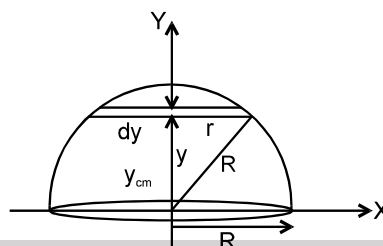
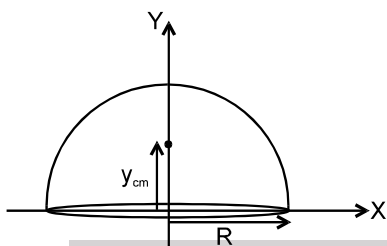

The mass dm of this disc can be given as $dm = \frac{3M}{2\pi R^3} \times \pi r^2 dy = \frac{3M}{2R^3} (R^2 - y^2) dy$

y_{cm} of the hemisphere is given as $y_{cm} = \frac{1}{M} \int_0^R dmy = \frac{1}{M} \int_0^R \frac{3M}{2R^3} (R^2 - y^2) dy y = \frac{3}{2R^3} \int_0^R (R^2 - y^2) y dy$

$$y_{cm} = \frac{3R}{8}$$

CENTER OF MASS OF A HOLLOW HEMISPHERE

A hollow hemisphere of mass M and radius R . Now we consider an elemental circular strip of angular width $d\theta$ at an angular distance θ from the base of the hemisphere. This strip will have an area.

$$dS = 2\pi R \cos \theta R d\theta$$

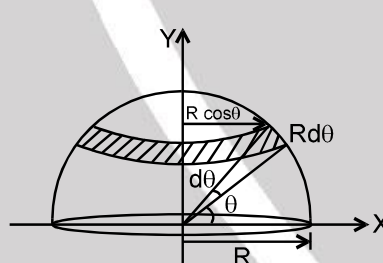
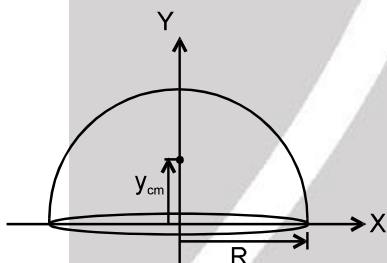

Its mass dm is given as

$$dm = \frac{M}{2\pi R^2} 2\pi R \cos \theta R d\theta$$

Here y -coordinate of this strip of mass dm can be taken as $R \sin \theta$. Now we can obtain the center of mass of the system as.

$$\begin{aligned} y_{cm} &= \frac{1}{M} \int_0^{\frac{\pi}{2}} dm R \sin \theta = \frac{1}{M} \int_0^{\frac{\pi}{2}} \left(\frac{M}{2\pi R^2} 2\pi R^2 \cos \theta d\theta \right) R \sin \theta \\ &= R \int_0^{\frac{\pi}{2}} \sin \theta \cos \theta d\theta \Rightarrow y_{cm} = \frac{R}{2} \end{aligned}$$

CENTER OF MASS OF A SOLID CONE

A solid cone has mass M , height H and base radius R . Obviously the center of mass of this cone will lie somewhere on its axis, at a height less than $H/2$. To locate the center of mass we consider an elemental disc of width dy and radius r , at a distance y from the apex of the cone. Let the mass of this disc be dm , which can be given as



$$dm = \frac{3M}{\pi R^2 H} \times \pi r^2 dy$$

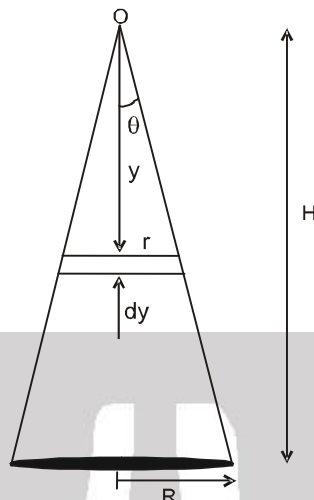

$$\text{here } y_{cm} \text{ can be given as } y_{cm} = \frac{1}{M} \int_0^H y dm = \frac{1}{M} \int_0^H \left(\frac{3M}{\pi R^2 H} \pi \left(\frac{Ry}{H} \right)^2 dy \right) y = \frac{3}{H^3} \int_0^H y^3 dy = \frac{3H}{4}$$

Solved Example

Example 6. Find out the center of mass of an isosceles triangle of base length a and altitude b . Assume that the mass of the triangle is uniformly distributed over its area.

Solution : To locate the center of mass of the triangle, we take a strip of width dx at a distance x from the vertex of the triangle. Length of this strip can be evaluated by similar triangles as $\ell = x \cdot (a/b)$

$$\text{Mass of the strip is } dm = \frac{2M}{ab} \ell dx$$

Distance of center of mass from the vertex of the

$$\text{triangle is } x_{cm} = \frac{1}{M} \int x dm = \int_0^b \frac{2x^2}{b^2} dx = \frac{2}{3} b$$

Proceeding in the similar manner, we can find the COM of certain rigid bodies. Center of mass of some well known rigid bodies are given below :

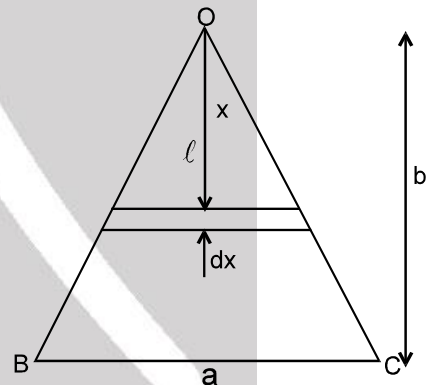

- Center of mass of a uniform rectangular, square or circular plate lies at its center. Axis of symmetry plane of symmetry.

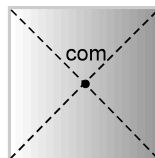
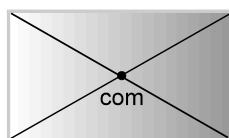

- For a lamina type (2-dimensional) body with uniform negligible thickness the formulae for finding the position of center of mass are as follows :

$$\vec{r}_{COM} = \frac{m_1 \vec{r}_1 + m_2 \vec{r}_2 + \dots}{m_1 + m_2 + \dots} = \frac{\rho A_1 t \vec{r}_1 + \rho A_2 t \vec{r}_2 + \dots}{\rho A_1 t + \rho A_2 t + \dots} \quad (\because m = \rho A t)$$

$$\text{or } \vec{r}_{COM} = \frac{A_1 \vec{r}_1 + A_2 \vec{r}_2 + \dots}{A_1 + A_2 + \dots}$$

Here, A stands for the area,



3. If some mass of area is removed from a rigid body, then the position of center of mass of the remaining portion is obtained from the following formulae :

$$(i) \quad \vec{r}_{COM} = \frac{m_1 \vec{r}_1 - m_2 \vec{r}_2}{m_1 - m_2} \quad \text{or} \quad \vec{r}_{COM} = \frac{A_1 \vec{r}_1 - A_2 \vec{r}_2}{A_1 - A_2}$$

$$(ii) \quad x_{COM} = \frac{m_1 x_1 - m_2 x_2}{m_1 - m_2} \quad \text{or} \quad x_{COM} = \frac{A_1 x_1 - A_2 x_2}{A_1 - A_2}$$

$$y_{COM} = \frac{m_1 y_1 - m_2 y_2}{m_1 - m_2} \quad \text{or} \quad y_{COM} = \frac{A_1 y_1 - A_2 y_2}{A_1 - A_2}$$

$$\text{and } z_{COM} = \frac{m_1 z_1 - m_2 z_2}{m_1 - m_2} \quad \text{or} \quad z_{COM} = \frac{A_1 z_1 - A_2 z_2}{A_1 - A_2}$$

Here, m_1 , A_1 , \vec{r}_1 , x_1 , y_1 and z_1 are the values for the whole mass while m_2 , A_2 , \vec{r}_2 , x_2 , y_2 and z_2 are the values for the mass which has been removed. Let us see two examples in support of the above theory.

Example 7. Find the position of center of mass of the uniform lamina shown in figure.

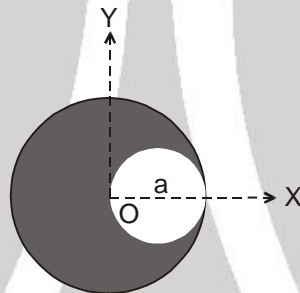

Solution :

Here, $A_1 =$ area of complete circle $= \pi a^2$

$$A_2 = \text{area of small circle} = \pi \left(\frac{a}{2}\right)^2 = \frac{\pi a^2}{4}$$

$(x_1, y_1) =$ coordinates of center of mass of large circle $= (0, 0)$

and $(x_2, y_2) =$ coordinates of center of mass of small circle $= \left(\frac{a}{2}, 0\right)$

$$\text{Using } x_{COM} = \frac{A_1 x_1 - A_2 x_2}{A_1 - A_2}$$

$$\text{we get } x_{COM} = \frac{-\frac{\pi a^2}{4} \left(\frac{a}{2}\right)}{\pi a^2 - \frac{\pi a^2}{4}} = \frac{-\left(\frac{1}{8}\right)}{\left(\frac{3}{4}\right)} a = -\frac{a}{6} \quad \text{and } y_{COM} = 0 \text{ as } y_1 \text{ and } y_2 \text{ both are zero.}$$

Therefore, coordinates of COM of the lamina shown in figure are $\left(-\frac{a}{6}, 0\right)$ **Ans.**



CENTER OF MASS OF SOME COMMON SYSTEMS

\Rightarrow A system of two point masses m_1 $r_1 = m_2$ r_2

The center of mass lies closer to the heavier mass.

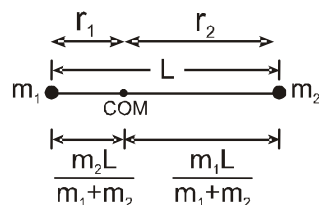

\Rightarrow Rectangular plate (By symmetry)



$$x_c = \frac{b}{2} \quad y_c = \frac{L}{2}$$

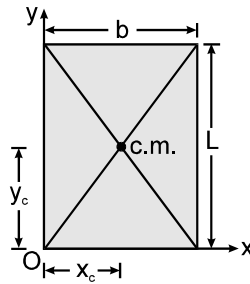

⇒ A triangular plate (By qualitative argument)

at the centroid : $y_c = \frac{h}{3}$

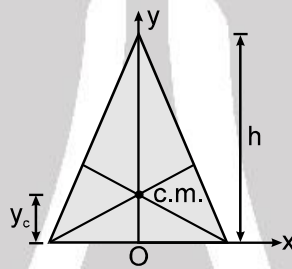

⇒ A semi-circular ring

$$y_c = \frac{2R}{\pi} \quad x_c = 0$$

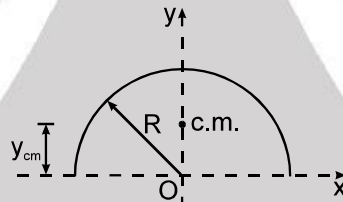

⇒ A quarter ring

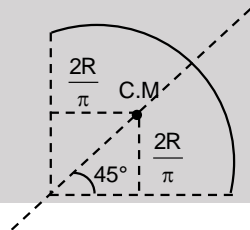

⇒ A semi-circular disc

$$y_c = \frac{4R}{3\pi} \quad x_c = 0$$

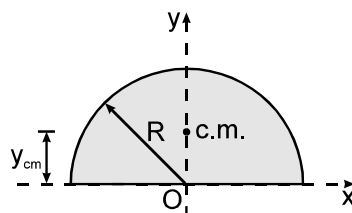



⇒ A quarter disc

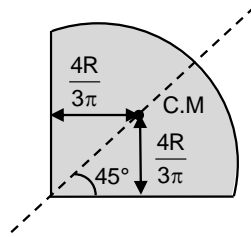

⇒ A hemispherical shell

$$y_c = \frac{R}{2} \quad x_c = 0$$

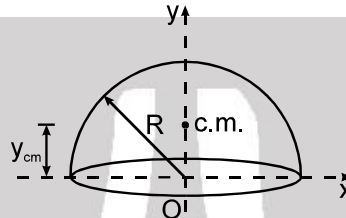

⇒ A solid hemisphere

$$y_c = \frac{3R}{8} \quad x_c = 0$$

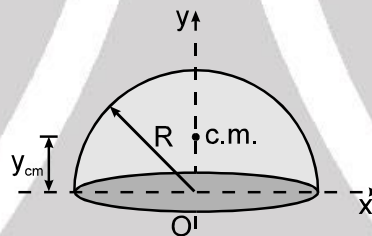

⇒ A circular cone (solid)

$$y_c = \frac{h}{4}$$

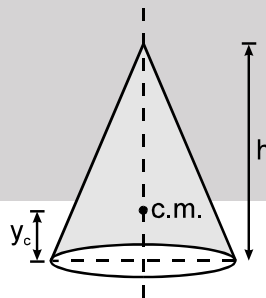

⇒ A circular cone (hollow)

$$y_c = \frac{h}{3}$$

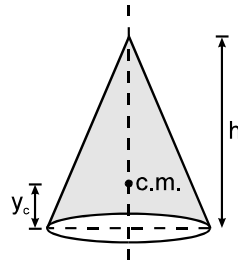

MOTION OF CENTER OF MASS AND CONSERVATION OF MOMENTUM :

Velocity of center of mass of system

$$\vec{v}_{cm} = \frac{m_1 \frac{d\vec{r}_1}{dt} + m_2 \frac{d\vec{r}_2}{dt} + m_3 \frac{d\vec{r}_3}{dt} + \dots + m_n \frac{d\vec{r}_n}{dt}}{M} = \frac{m_1 \vec{v}_1 + m_2 \vec{v}_2 + m_3 \vec{v}_3 + \dots + m_n \vec{v}_n}{M}$$

Here numerator of the right hand side term is the total momentum of the system i.e., summation of momentum of the individual component (particle) of the system

Hence velocity of center of mass of the system is the ratio of momentum of the system to the mass of the system.

$$\therefore \vec{P}_{\text{System}} = M \vec{v}_{cm}$$

Acceleration of center of mass of system

$$\begin{aligned} \vec{a}_{cm} &= \frac{m_1 \frac{d\vec{v}_1}{dt} + m_2 \frac{d\vec{v}_2}{dt} + m_3 \frac{d\vec{v}_3}{dt} + \dots + m_n \frac{d\vec{v}_n}{dt}}{M} = \frac{m_1 \vec{a}_1 + m_2 \vec{a}_2 + m_3 \vec{a}_3 + \dots + m_n \vec{a}_n}{M} \\ &= \frac{\text{Net force on system}}{M} = \frac{\text{Net External Force} + \text{Net internal Force}}{M} = \frac{\text{Net External Force}}{M} \end{aligned}$$

(\because action and reaction both of an internal force must be within the system. Vector summation will cancel all internal forces and hence net internal force on system is zero)

$$\therefore \vec{F}_{\text{ext}} = M \vec{a}_{cm}$$

where \vec{F}_{ext} is the sum of the 'external' forces acting on the system. The internal forces which the particles exert on one another play absolutely no role in the motion of the center of mass.

If no external force is acting on a system of particles, the acceleration of center of mass of the system will be zero. If $a_c = 0$, it implies that v_c must be a constant and if v_{cm} is a constant, it implies that the total momentum of the system must remain constant. It leads to the principle of conservation of momentum in absence of external forces.

If $\vec{F}_{\text{ext}} = 0$ then \vec{v}_{cm} constant

“If resultant external force is zero on the system, then the net momentum of the system must remain constant”.

Motion of COM in a moving system of particles :

(1) COM at rest :

If $F_{\text{ext}} = 0$ and $V_{cm} = 0$, then COM remains at rest. Individual components of the system may move and have non-zero momentum due to mutual forces (internal), but the net momentum of the system remains zero.

- (i) All the particles of the system are at rest.
- (ii) Particles are moving such that their net momentum is zero.

Example:

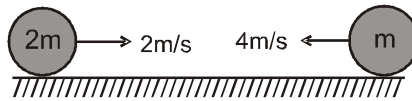

- (iii) A bomb at rest suddenly explodes into various smaller fragments, all moving in different directions then, since the explosive forces are internal & there is no external force on the system for explosion therefore, the COM of the bomb will remain at the original position and the fragment fly such that their net momentum remains zero.
- (iv) Two men standing on a frictionless platform, push each other, then also their net momentum remains zero because the push forces are internal for the two men system.
- (v) A boat floating in a lake, also has net momentum zero if the people on it changes their position, because the friction force required to move the people is internal of the boat system.
- (vi) Objects initially at rest, if moving under mutual forces (electrostatic or gravitation) also have net momentum zero.
- (vii) A light spring of spring constant k kept compressed between two blocks of masses m_1 and m_2 on a smooth horizontal surface. When released, the blocks acquire velocities in opposite directions, such that the net momentum is zero.
- (viii) In a fan, all particles are moving but COM is at rest

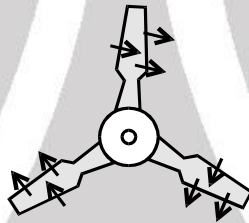

(2) COM moving with uniform velocity :

If $F_{\text{ext}} = 0$, then V_{cm} remains constant therefore, net momentum of the system also remains conserved. Individual components of the system may have variable velocity and momentum due to mutual forces (internal), but the net momentum of the system remains constant and COM continues to move with the initial velocity.

- (i) All the particles of the system are moving with same velocity.
e.g.: A car moving with uniform speed on a straight road, has its COM moving with a constant velocity.



- (ii) Internal explosions / breaking does not change the motion of COM and net momentum remains conserved. A bomb moving in a straight line suddenly explodes into various smaller fragments, all moving in different directions then, since the explosive forces are internal & there is no external force on the system for explosion therefore, the COM of the bomb will continue the original motion and the fragment fly such that their net momentum remains conserved.
- (iii) Man jumping from cart or buggy also exert internal forces therefore net momentum of the system and hence, Motion of COM remains conserved.
- (iv) Two moving blocks connected by a light spring on a smooth horizontal surface. If the acting forces is only due to spring then COM will remain in its motion and momentum will remain conserved.
- (v) Particles colliding in absence of external impulsive forces also have their momentum conserved.



(3) COM moving with acceleration :

If an external force is present then COM continues its original motion as if the external force is acting on it, irrespective of internal forces.

Example:

Projectile motion : An axe thrown in air at an angle θ with the horizontal will perform a complicated motion of rotation as well as parabolic motion under the effect of gravitation

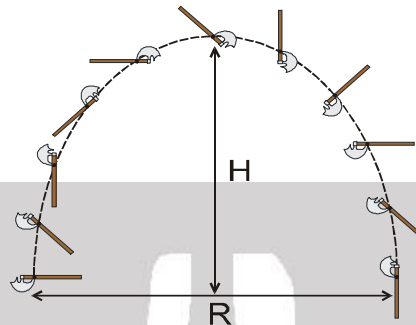

The motion of axe is complicated but the COM is moving in a parabolic motion.

$$H_{\text{com}} = \frac{u^2 \sin^2 \theta}{2g}$$

$$R_{\text{com}} = \frac{u^2 \sin 2\theta}{g} \quad T = \frac{2u \sin \theta}{g}$$

Example :

Circular Motion : A rod hinged at an end, rotates, then its COM performs circular motion. The centripetal force (F_c) required in the circular motion is assumed to be acting on the COM.

$$F_c = m\omega^2 R_{\text{COM}}$$

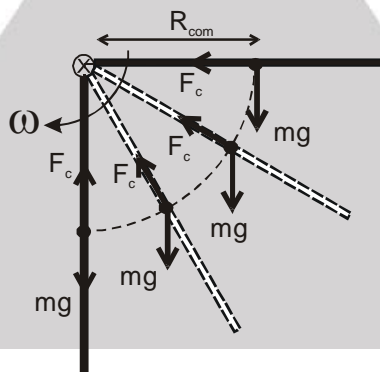

Solved Example

Example 8. A projectile is fired at a speed of 100 m/s at an angle of 37° above the horizontal. At the highest point, the projectile breaks into two parts of mass ratio 1 : 3, the lighter piece coming to rest. Find the distance from the launching point to the point where the heavier piece lands.

Solution : Internal force do not effect the motion of the center of mass, the center of mass hits the ground at the position where the original projectile would have landed. The range of the original projectile is,

$$x_{\text{COM}} = \frac{2u^2 \sin \theta \cos \theta}{g} = \frac{2 \times 10^4 \times \frac{3}{5} \times \frac{4}{5}}{10} \text{ m}$$

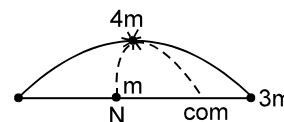



$$= 960 \text{ m}$$

The center of mass will hit the ground at this position. As the smaller block comes to rest after breaking, it falls down vertically and hits the ground at half of the range, i.e., at $x = 480 \text{ m}$. If the heavier block hits the ground at x_2 , then

$$x_{\text{COM}} = \frac{m_1 x_1 + m_2 x_2}{m_1 + m_2}$$

$$960 = \frac{(m)(480) + (3m)(x_2)}{(m + 3m)}$$

$$x_2 = 1120 \text{ m} \quad \text{Ans.}$$



Momentum Conservation :

The total linear momentum of a system of particles is equal to the product of the total mass of the system and the velocity of its center of mass. $\vec{P} = M \vec{v}_{\text{cm}}$

$$\vec{F}_{\text{ext}} = \frac{d\vec{P}}{dt}$$

$$\text{If } \vec{F}_{\text{ext}} = 0 \Rightarrow \frac{d\vec{P}}{dt} = 0 ; \vec{P} = \text{constant}$$

When the vector sum of the external forces acting on a system is zero, the total linear momentum of the system remains constant.

$$\vec{P}_1 + \vec{P}_2 + \vec{P}_3 + \dots + \vec{P}_n = \text{constant.}$$

Solved Examples

Example 9. A shell is fired from a cannon with a speed of 100 m/s at an angle 60° with the horizontal (positive x -direction). At the highest point of its trajectory, the shell explodes into two equal fragments. One of the fragments moves along the negative x -direction with a speed of 50 m/s . What is the speed of the other fragment at the time of explosion.

Solution : As we know in absence of external force the motion of center of mass of a body remains unaffected. Thus, here the center of mass of the two fragments will continue to follow the original projectile path. The velocity of the shell at the highest point of trajectory is

$$v_M = u \cos \theta = 100 \times \cos 60^\circ = 50 \text{ m/s}$$

Let v_1 be the speed of the fragment which moves along the negative x -direction and the other fragment has speed v_2 . Which must be along positive x -direction. Now from momentum conservation, we have

$$mv = \frac{-m}{2} v_1 + \frac{m}{2} v_2 \quad \text{or} \quad 2v = v_2 - v_1$$

$$\text{or } v_2 = 2v + v_1 = (2 \times 50) + 50 = 150 \text{ m/s}$$

Example 10. A man of mass m is standing on a platform of mass M kept on smooth ice. If the man starts moving on the platform with a speed v relative to the platform, with what velocity relative to the ice does the platform recoil ?

Solution : Consider the situation shown in figure. Suppose the man moves at a speed w towards right and the platform recoils at a speed V towards left, both relative to the ice. Hence, the speed of the man relative to the platform is $V + w$. By the question,

$$V + w = v, \text{ or } w = v - V \quad \dots(i)$$



Taking the platform and the man to be the system, there is no external horizontal force on the system. The linear momentum of the system remains constant. Initially both the man and the platform were at rest. Thus,

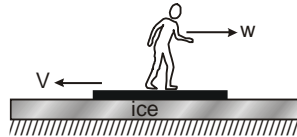

$$0 = MV - mw \quad \text{or} \quad MV = m(v - V) \quad [\text{Using (i)}]$$

$$\text{or, } V = \frac{mv}{M+m}$$

Example 11. A flat car of mass M is at rest on a frictionless floor with a child of mass m standing at its edge. If child jumps off from the car towards right with an initial velocity u , with respect to the car, find the velocity of the car after its jump.

Solution : Let car attains a velocity v , and the net velocity of the child with respect to earth will be $u - v$, as u is its velocity with respect to car.

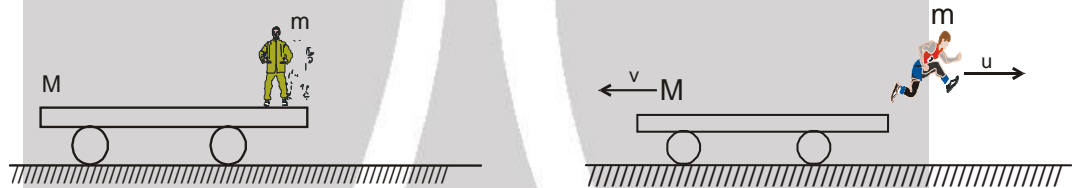

Initially, the system was at rest, thus according to momentum conservation, momentum after jump must be zero, as $m(u - v) = Mv$

$$v = \frac{mu}{m+M}$$

Example 12. A flat car of mass M with a child of mass m is moving with a velocity v_1 on a friction less surface. The child jumps in the direction of motion of car with a velocity u with respect to car. Find the final velocities of the child and that of the car after jump.

Solution : This case is similar to the previous example, except now the car is moving before jump. Here also no external force is acting on the system in horizontal direction, hence momentum remains conserved in this direction. After jump car attains a velocity v_2 in the same direction, which is less than v_1 , due to backward push of the child for jumping. After jump child attains a velocity $u + v_2$ in the direction of motion of car, with respect to ground.

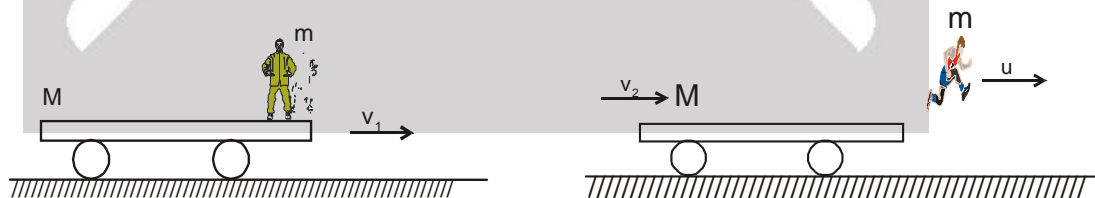

According to momentum conservation $(M + m)v_1 = Mv_2 + m(u + v_2)$

$$\text{Velocity of car after jump is } v_2 = \frac{(M+m)v_1 - mu}{M+m}$$

$$\text{Velocity of child after jump is } u + v_2 = \frac{(M+m)v_1 + (M)u}{M+m}$$

Example 13. Each of the blocks shown in figure has mass 1 kg. The rear block moves with a speed of 2 m/s towards the front block kept at rest. The spring attached to the front block is light and has a spring constant 50 N/m. Find the maximum compression of the spring. Assume, on a friction less surface

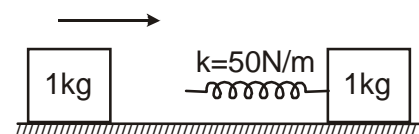



Solution : Maximum compression will take place when the blocks move with equal velocity. As no net external horizontal force acts on the system of the two blocks, the total linear momentum will remain constant. If V is the common speed at maximum compression, we have,
 $(1 \text{ kg}) (2 \text{ m/s}) = (1 \text{ kg})V + (1 \text{ kg})V$ or, $V = 1 \text{ m/s}$.

$$\text{Initial kinetic energy} = \frac{1}{2} (1 \text{ kg}) (2 \text{ m/s})^2 = 2 \text{ J}.$$

$$\text{Final kinetic energy} = \frac{1}{2} (1 \text{ kg}) (1 \text{ m/s})^2 + \frac{1}{2} (1 \text{ kg}) (1 \text{ m/s})^2 = 1 \text{ J}$$

The kinetic energy lost is stored as the elastic energy in the spring.

$$\text{Hence, } \frac{1}{2} (50 \text{ N/m}) x^2 = 2 \text{ J} - 1 \text{ J} = 1 \text{ J} \quad \text{or,} \quad x = 0.2 \text{ m}$$

Example 14. Figure shows two blocks of masses 5 kg and 2 kg placed on a frictionless surface and connected with a spring. An external kick gives a velocity 14 m/s to the heavier block towards the lighter one. Deduce (a) velocity gained by the center of mass and (b) the separate velocities of the two blocks with respect to center of mass just after the kick.

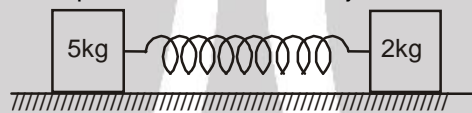

Solution : (a) Velocity of center of mass is $v_{cm} = \frac{5 \times 14 + 2 \times 0}{5 + 2} = 10 \text{ m/s}$

(b) Due to kick on 5 kg block, it starts moving with a velocity 14 m/s immediately, but due to inertia 2 kg block remains at rest, at that moment. Thus, velocity of 5 kg block with respect to the center of mass is $v_1 = 14 - 10 = 4 \text{ m/s}$ and the velocity of 2 kg block w.r.t. to center of mass is $v_2 = 0 - 10 = -10 \text{ m/s}$

Example 15. A light spring of spring constant k is kept compressed between two blocks of masses m and M on a smooth horizontal surface. When released, the blocks acquire velocities in opposite directions. The spring loses contact with the blocks when it acquires natural length. If the spring was initially compressed through a distance x , find the final speeds of the two blocks.

Solution : Consider the two blocks plus the spring to be the system. No external force acts on this system in horizontal direction. Hence, the linear momentum will remain constant. Suppose, the block of mass M moves with a speed v_1 and the other block with a speed v after losing contact with the spring. From conservation of linear momentum in horizontal direction we have

$$Mv_1 - mv_2 = 0 \quad \text{or} \quad v_1 = \frac{m}{M} v_2, \quad \dots(i)$$

$$\text{Initially, the energy of the system} = \frac{1}{2} kx^2$$

$$\text{Finally, the energy of the system} = \frac{1}{2} mv_2^2 + \frac{1}{2} Mv_1^2$$

As there is no friction, mechanical energy will remain conserved.

$$\text{Therefore, } \frac{1}{2} mv_2^2 + \frac{1}{2} Mv_1^2 = \frac{1}{2} kx^2 \quad \dots(ii)$$

Solving Eqs. (i) and (ii), we get

$$\text{or, } v_2 = \left[\frac{kM}{m(M+m)} \right]^{1/2} x \quad \text{and} \quad v_1 = \left[\frac{km}{M(M+m)} \right]^{1/2} x \quad \text{Ans.}$$



Example 16. A block of mass m is connected to another block of mass M by a massless spring of spring constant k . The blocks are kept on a smooth horizontal plane and are at rest. The spring is unstretched when a constant force F starts acting on the block of mass M to pull it. Find the maximum extension of the spring.

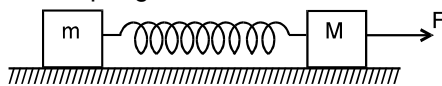

Solution : We solve the situation in the reference frame of center of mass. As only F is the external force acting on the system, due to this force, the acceleration of the center of mass is $F/(M + m)$. Thus with respect to center of mass there is a Pseudo force on the two masses in opposite direction, the free body diagram of m and M with respect to center of mass (taking center of mass at rest) is shown in figure.



Taking center of mass at rest, if m moves maximum by a distance x_1 and M moves maximum by a distance x_2 , then the work done by external forces (including Pseudo force) will be

$$W = \frac{mF}{m+M} \cdot x_1 + \left(F - \frac{MF}{m+M} \right) \cdot x_2 = \frac{mF}{m+M} \cdot (x_1 + x_2)$$

This work is stored in the form of potential energy of the spring as $U = \frac{1}{2} k(x_1 + x_2)^2$

Thus on equating we get the maximum extension in the spring, as after this instant the spring starts contracting.

$$\frac{1}{2} k(x_1 + x_2)^2 = \frac{mF}{m+M} \cdot (x_1 + x_2)$$

$$x_{\max} = x_1 + x_2 = \frac{2mF}{k(m+M)}$$



IMPULSE

Impulse of a force \vec{F} acting on a body for the time interval $t = t_1$ to $t = t_2$ is defined as :

$$\vec{I} = \int_{t_1}^{t_2} \vec{F} dt \quad \Rightarrow \quad \vec{I} = \int \vec{F} dt = \int m \frac{d\vec{v}}{dt} dt = \int m d\vec{v}$$

$$\vec{I} = m(\vec{v}_2 - \vec{v}_1) = \Delta \vec{P} = \text{change in momentum due to force}$$

$$\text{Also, } \vec{I}_{\text{Res}} = \int_{t_1}^{t_2} \vec{F}_{\text{Res}} dt = \Delta \vec{P} \quad \text{(impulse - momentum theorem)}$$

Note : Impulse applied to an object in a given time interval can also be calculated from the area under force time (F - t) graph in the same time interval.

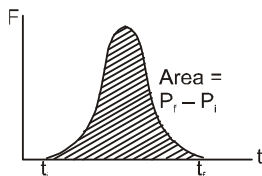

Instantaneous Impulse :

There are many cases when a force acts for such a short time that the effect is instantaneous, e.g., a bat striking a ball. In such cases, although the magnitude of the force and the time for which it acts may





each be unknown but the value of their product (i.e., impulse) can be known by measuring the initial and final momenta. Thus, we can write.

$$\vec{I} = \int \vec{F} dt = \Delta \vec{P} = \vec{P}_f - \vec{P}_i$$

Important Points :

- (1) It is a vector quantity.
- (2) Dimensions = [MLT⁻¹]
- (3) SI unit = kg m/s
- (4) Direction is along change in momentum.
- (5) Magnitude is equal to area under the F-t. graph.
- (6) $\vec{I} = \int \vec{F} dt = \vec{F}_{av} \int dt = \vec{F}_{av} \Delta t$
- (7) It is not a property of a particle, but it is a measure of the degree to which an external force changes the momentum of the particle.

Solved Example

Example 17. The hero of a stunt film fires 50 g bullets from a machine gun, each at a speed of 1.0 km/s. If he fires 20 bullets in 4 seconds, what average force does he exert against the machine gun during this period.

Solution : The momentum of each bullet
 $= (0.050 \text{ kg}) (1000 \text{ m/s}) = 50 \text{ kg-m/s}$
 The gun has been imparted this much amount of momentum by each bullet fired. Thus, the rate of change of momentum of the gun
 $= \frac{(50 \text{ kg-m/s}) \times 20}{4 \text{ s}} = 250 \text{ N}$.

In order to hold the gun, the hero must exert a force of 250 N against the gun.



Impulsive force :

A force, of relatively higher magnitude and acting for relatively shorter time, is called impulsive force. An impulsive force can change the momentum of a body in a finite magnitude in a very short time interval. **Impulsive force** is a relative term. There is no clear boundary between an impulsive and Non-Impulsive force.

Note : Usually colliding forces are impulsive in nature.

Since, the application time is very small, hence, very little motion of the particle takes place.

Important points :

1. Gravitational force and spring force are always non-Impulsive.
2. Normal, tension and friction are case dependent.
3. An impulsive force can only be balanced by another impulsive force.
1. **Impulsive Normal :** In case of collision, normal forces at the surface of collision are always impulsive

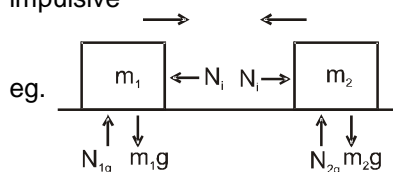

$N_i = \text{Impulsive}; N_g = \text{Non-impulsive}$

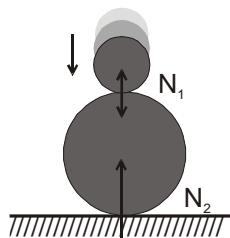

Both normals are Impulsive

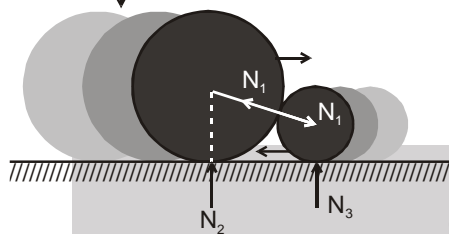

$N_1, N_3 =$ Impulsive; $N_2 =$ non-impulsive

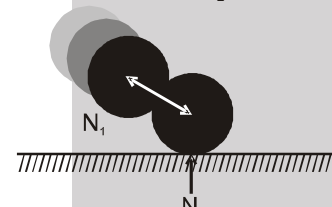

Both normals are Impulsive

2. **Impulsive Friction** : If the normal between the two objects is impulsive, then the friction between the two will also be impulsive.

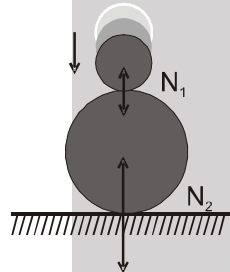

Friction at both surfaces is impulsive

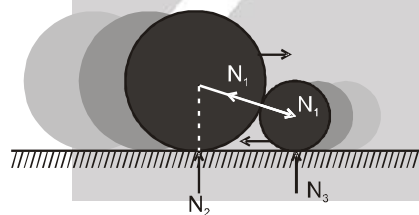

Friction due to N_2 is non-impulsive and due to N_3 and N_1 are impulsive.

3. **Impulsive Tensions** : When a string jerks, equal and opposite tension act suddenly at each end. Consequently equal and opposite impulses act on the bodies attached with the string in the direction of the string. There are two cases to be considered.

- (a) **One end of the string is fixed** : The impulse which acts at the fixed end of the string cannot change the momentum of the fixed object there. The object attached to the free end however will undergo a change in momentum in the direction of the string. The momentum remains unchanged in a direction perpendicular to the string where no impulsive forces act.
- (b) **Both ends of the string attached to movable objects** : In this case equal and opposite impulses act on the two objects, producing equal and opposite changes in momentum. The total momentum of the system therefore remains constant, although the momentum of each individual object is changed in the direction of the string. Perpendicular to the string however, no impulse acts and the momentum of each particle in this direction is unchanged.

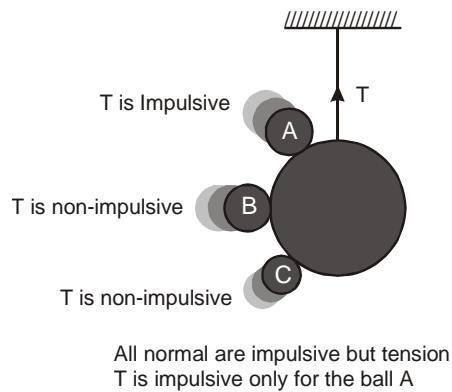

For this example : In case of rod, Tension is always impulsive and in case of spring, Tension is always non-impulsive.

Solved Example

Example 18. A block of mass m and a pan of equal mass are connected by a string going over a smooth light pulley. Initially the system is at rest when a particle of mass m falls on the pan and sticks to it. If the particle strikes the pan with a speed v , find the speed with which the system moves just after the collision.

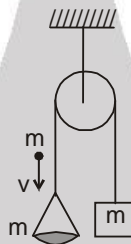

Solution :

Let the required speed is V .

Further, let $J_1 =$ impulse between particle and pan

and $J_2 =$ impulse imparted to the block and the pan by the string

Using, impulse = change in momentum

$$\text{For particle } J_1 = mv - mV \quad \dots (i)$$

$$\text{For pan } J_1 - J_2 = mV \quad \dots (ii)$$

$$\text{For block } J_2 = mV \quad \dots (iii)$$

Solving, these three equation, we get

$$V = \frac{v}{3}$$

Ans.

Alternative Solution :

Applying conservation of linear momentum along the string;

$$mv = 3mV$$

$$\text{we get, } V = \frac{v}{3}$$

Ans.

Example 19. Two identical block A and B, connected by a massless string are placed on a frictionless horizontal plane. A bullet having same mass, moving with speed u strikes block B from behind as shown. If the bullet gets embedded into the block B then find :

- The velocity of A, B, C after collision.
- Impulse on A due to tension in the string
- Impulse on C due to normal force of collision.
- Impulse on B due to normal force of collision.

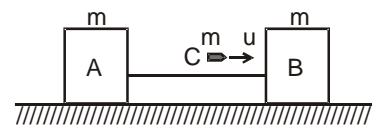



Solution : (a) By Conservation of linear momentum $v = \frac{u}{3}$

$$(b) \int T dt = \frac{mu}{3}$$

$$(c) \int N dt = m \left(\frac{u}{3} - u \right) = \frac{-2mu}{3}$$

$$(d) \int (N - T) dt = \int N dt - \int T dt = \frac{mu}{3}$$

$$\int N dt = \frac{2mu}{3}$$



COLLISION OR IMPACT

Collision is an event in which an impulsive force acts between two or more bodies for a short time, which results in change of their velocities.

Note :

- In a collision, particles may or may not come in physical contact.
- The duration of collision, Δt is negligible as compared to the usual time intervals of observation of motion.
- In a collision the effect of external non impulsive forces such as gravity are not taken into account as due to small duration of collision (Δt) average impulsive force responsible for collision is much larger than external forces acting on the system.

The collision is infact a redistribution of total momentum of the particles. Thus, law of conservation of linear momentum is indispensable in dealing with the phenomenon of collision between particles.

Line of Impact

The line passing through the common normal to the surfaces in contact during impact is called line of impact. The force during collision acts along this line on both the bodies.

Direction of Line of impact can be determined by:

- Geometry of colliding objects like spheres, discs, wedge etc.
- Direction of change of momentum.

If one particle is stationary before the collision then the line of impact will be along its motion after collision.

Classification of collisions

(a) On the basis of line of impact

- Head-on collision :** If the velocities of the colliding particles are along the same line before and after the collision.
- Oblique collision :** If the velocities of the colliding particles are along different lines before and after the collision.

(b) On the basis of energy :

- Elastic collision :** In an elastic collision, the colliding particles regain their shape and size completely after collision. i.e., no fraction of mechanical energy remains stored as deformation potential energy in the bodies. Thus, kinetic energy of system after collision is equal to kinetic energy of system before collision. Thus in addition to the linear momentum, kinetic energy also remains conserved before and after collision.
- Inelastic collision :** In an inelastic collision, the colliding particles do not regain their shape and size completely after collision. Some fraction of mechanical energy is retained by the colliding particles in the form of deformation potential energy. Thus, the kinetic energy of the particles after collision is not equal to that of before collision. However, in the absence of external forces, law of conservation of linear momentum still holds good.



- (iii) **Perfectly inelastic** : If velocity of separation along the line of impact just after collision becomes zero then the collision is perfectly inelastic. Collision is said to be **perfectly inelastic** if both the particles stick together after collision and move with same velocity,

Note : Actually collision between all real objects are neither perfectly elastic nor perfectly inelastic, its inelastic in nature.

Examples of line of impact and collisions based on line of impact

- (i) Two balls A and B are approaching each other such that their centers are moving along line CD.

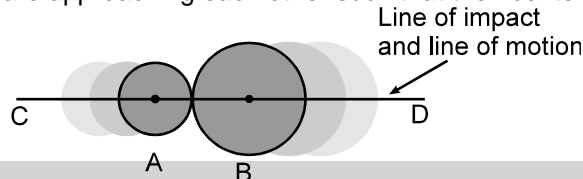

Head on Collision

- (ii) Two balls A and B are approaching each other such that their center are moving along dotted lines as shown in figure.

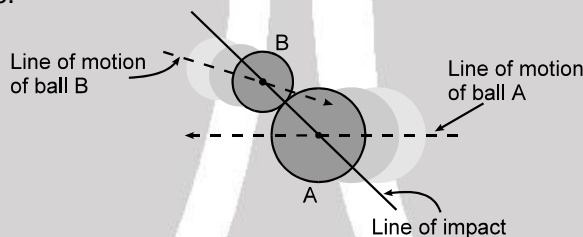

Oblique Collision

- (iii) Ball is falling on a stationary wedge.

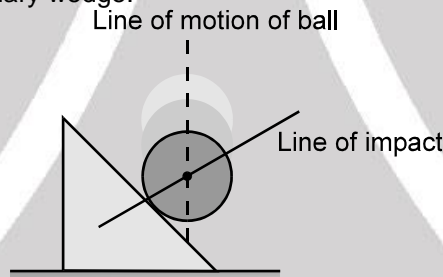

COEFFICIENT OF RESTITUTION (e)

The coefficient of restitution is defined as the ratio of the impulses of reformation and deformation of either body.

$$e = \frac{\text{Impulse of reformation}}{\text{Impulse of deformation}} = \frac{\int F_r dt}{\int F_d dt}$$

$$= \frac{\text{Velocity of separation along line of impact}}{\text{Velocity of approach along line of impact}}$$

The most general expression for coefficient of restitution is

$$e = \frac{\text{velocity of separation of points of contact along line of impact}}{\text{velocity of approach of point of contact along line of impact}}$$

Example for calculation of e

Two smooth balls A and B approaching each other such that their centers are moving along line CD in absence of external impulsive force. The velocities of A and B just before collision be u_1 and u_2 respectively. The velocities of A and B just after collision be v_1 and v_2 respectively.

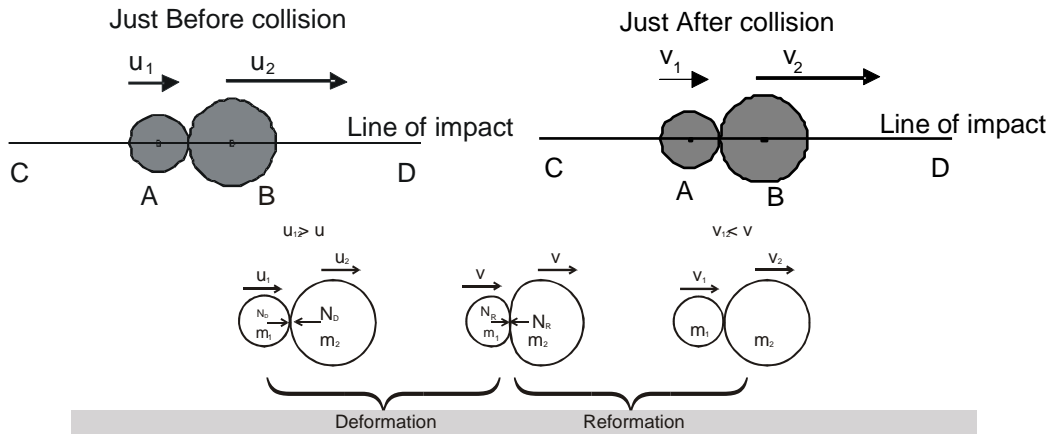

$\therefore F_{\text{ext}} = 0$ momentum is conserved for the system.

$$\Rightarrow m_1 u_1 + m_2 u_2 = (m_1 + m_2)v = m_1 v_1 + m_2 v_2$$

$$\Rightarrow v = \frac{m_1 u_1 + m_2 u_2}{m_1 + m_2} = \frac{m_1 v_1 + m_2 v_2}{m_1 + m_2} \quad \dots\dots(1)$$

Impulse of Deformation :

J_D = change in momentum of any one body during deformation.

$$= m_2 (v - u_2) \quad \text{for } m_2$$

$$= m_1 (-v + u_1) \quad \text{for } m_1$$

Impulse of Reformation :

J_R = change in momentum of any one body during Reformation.

$$= m_2 (v_2 - v) \quad \text{for } m_2$$

$$= m_1 (v - v_1) \quad \text{for } m_1$$

$$e = \frac{\text{Impulse of Reformation } (\bar{J}_R)}{\text{Impulse of Deformation } (\bar{J}_D)} = \frac{v_2 - v_1}{u_1 - u_2} = \frac{\text{Velocity of separation along line of impact}}{\text{Velocity of approach along line of impact}}$$

Note : e is independent of shape and mass of object but depends on the material. The coefficient of restitution is constant for a pair of materials.

- (a) $e = 1$ Impulse of Reformation = Impulse of Deformation
 Velocity of separation = Velocity of approach
 Kinetic energy of particles after collision may be equal to that of before collision.
 Collision is elastic.
- (b) $e = 0$ Impulse of Reformation = 0
 Velocity of separation = 0
 Kinetic energy of particles after collision is not equal to that of before collision.
 Collision is perfectly inelastic.
- (c) $0 < e < 1$ Impulse of Reformation < Impulse of Deformation
 Velocity of separation < Velocity of approach
 Kinetic energy of particles after collision is not equal to that of before collision.
 Collision is Inelastic.

Note : In case of contact collisions e is always less than unity.

$$\therefore 0 \leq e \leq 1$$



Important Point :

In case of elastic collision, if rough surface is present then $k_f < k_i$ (because friction is impulsive).
Where, k is Kinetic Energy.

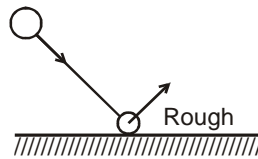

A particle 'B' moving along the dotted line collides with a rod also in state of motion as shown in the figure. The particle B comes in contact with point C on the rod.

To write down the expression for coefficient of restitution e , we first draw the line of impact. Then we resolve the components of velocities of points of contact of both the bodies along line of impact just before and just after collision.

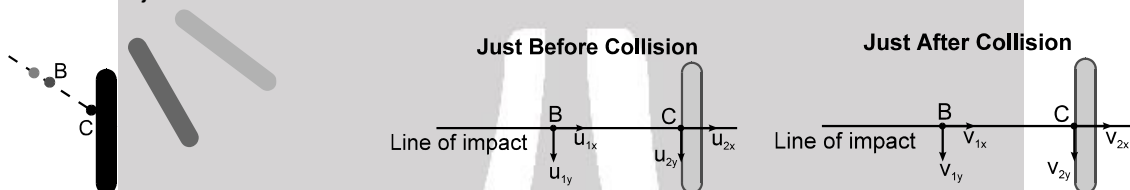

$$\text{Then } e = \frac{v_{2x} - v_{1x}}{u_{1x} - u_{2x}}$$

Collision in one dimension (Head on)



$$e = \frac{v_2 - v_1}{u_1 - u_2} \Rightarrow (u_1 - u_2)e = (v_2 - v_1)$$

By momentum conservation, $m_1u_1 + m_2u_2 = m_1v_1 + m_2v_2$

$$v_2 = v_1 + e(u_1 - u_2) \quad \text{and} \quad v_1 = \frac{m_1u_1 + m_2u_2 - m_2e(u_1 - u_2)}{m_1 + m_2}$$

$$v_2 = \frac{m_1u_1 + m_2u_2 + m_1e(u_1 - u_2)}{m_1 + m_2}$$

Special Case :

(1) $e = 0 \Rightarrow v_1 = v_2$

\Rightarrow for perfectly inelastic collision, both the bodies, move with same vel. after collision.

(2) $e = 1$

and $m_1 = m_2 = m$,

we get $v_1 = u_2$ and $v_2 = u_1$

i.e., when two particles of equal mass collide elastically and the collision is head on, they exchange their velocities., e.g.

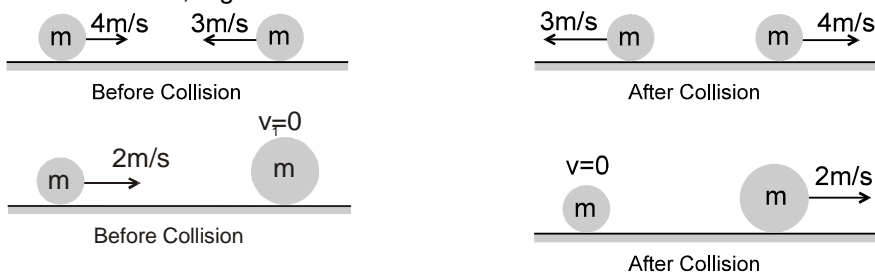

(3) $m_1 \gg m_2$

$$m_1 + m_2 = m_1 \text{ and } \frac{m_2}{m_1} = 0 \Rightarrow v_1 = u_1 \text{ No change and } v_2 = u_1 + e(u_1 - u_2)$$

Solved Example

Example 20. Two identical balls are approaching towards each other on a straight line with velocity 2 m/s and 4 m/s respectively. Find the final velocities, after elastic collision between them.

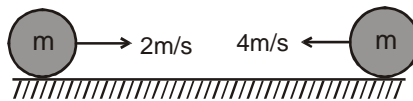

Solution : The two velocities will be exchanged and the final motion is reverse of initial motion for both.

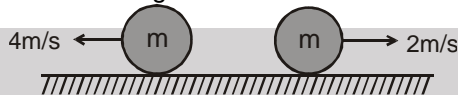

Example 21. Three balls A, B and C of same mass 'm' are placed on a frictionless horizontal plane in a straight line as shown. Ball A is moved with velocity u towards the middle ball B. If all the collisions are elastic then, find the final velocities of all the balls.

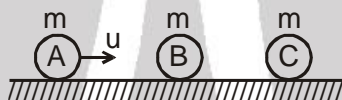

Solution : A collides elastically with B and comes to rest but B starts moving with velocity u

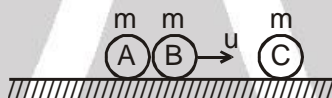

After a while B collides elastically with C and comes to rest but C starts moving with velocity u

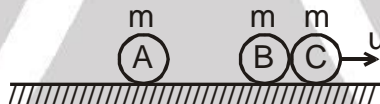

\therefore Final velocities

$$V_A = 0 ;$$

$$V_B = 0 \text{ and } V_C = u$$

Ans.

Example 22. Four identical balls A, B, C and D are placed in a line on a frictionless horizontal surface. A and D are moved with same speed 'u' towards the middle as shown. Assuming elastic collisions, find the final velocities.



Solution : A and D collides elastically with B and C respectively and come to rest but B and C starts moving with velocity u towards each other as shown

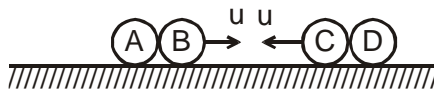

B and C collides elastically and exchange their velocities to move in opposite directions

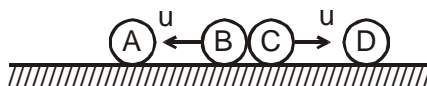

Now, B and C collides elastically with A and D respectively and come to rest but A and D starts moving with velocity u away from each other as shown

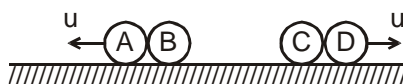

\therefore Final velocities $V_A = u$ (\leftarrow); $V_B = 0$; $V_C = 0$ and $V_D = u$ (\rightarrow)

Ans.



Example 23. Two particles of mass m and $2m$ moving in opposite directions on a frictionless surface collide elastically with velocity v and $2v$ respectively. Find their velocities after collision, also find the fraction of kinetic energy lost by the colliding particles.



Solution : Let the final velocities of m and $2m$ be v_1 and v_2 respectively as shown in the figure:



By conservation of momentum : $m(2v) + 2m(-v) = m(v_1) + 2m(v_2)$

$$\text{or } 0 = mv_1 + 2mv_2$$

$$\text{or } v_1 + 2v_2 = 0 \quad \dots(1)$$

and since the collision is elastic:

$$v_2 - v_1 = 2v - (-v)$$

$$\text{or } v_2 - v_1 = 3v \quad \dots(2)$$

Solving the above two equations, we get,

$$v_2 = v \text{ and } v_1 = -2v$$

Ans.

i.e., the mass $2m$ returns with velocity v while the mass m returns with velocity $2v$ in the direction shown in figure:



The collision was elastic therefore, no kinetic energy is lost, $KE_{\text{loss}} = KE_i - KE_f$

$$\text{or, } \left(\frac{1}{2}m(2v)^2 + \frac{1}{2}(2m)(-v)^2 \right) - \left(\frac{1}{2}m(-2v)^2 + \frac{1}{2}(2m)v^2 \right) = 0$$

Example 24. On a frictionless surface, a ball of mass m moving at a speed v makes a head on collision with an identical ball at rest. The kinetic energy of the balls after the collision is $3/4$ th of the original. Find the coefficient of restitution.

Solution : As we have seen in the above discussion, that under the given conditions :

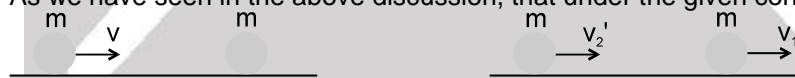

Before Collision

After Collision

By using conservation of linear momentum and equation of e , we get,

$$v_1' = \left(\frac{1+e}{2} \right) v \quad \text{and} \quad v_2' = \left(\frac{1-e}{2} \right) v$$

$$\text{Given that } K_f = \frac{3}{4} K_i \quad \text{or} \quad \frac{1}{2}mv_1'^2 + \frac{1}{2}mv_2'^2 = \frac{3}{4} \left(\frac{1}{2}mv^2 \right)$$

Substituting the value, we get

$$\left(\frac{1+e}{2} \right)^2 + \left(\frac{1-e}{2} \right)^2 = \frac{3}{4} \quad \text{or} \quad e = \frac{1}{\sqrt{2}} \quad \text{Ans.}$$



Example 25. A block of mass 2 kg is pushed towards a very heavy object moving with 2 m/s closer to the block (as shown). Assuming elastic collision and frictionless surfaces, find the final velocities of the blocks.

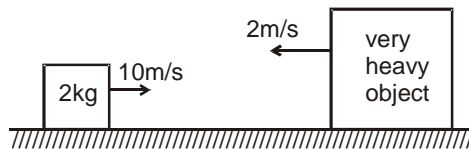

Solution : Let v_1 and v_2 be the final velocities of 2kg block and heavy object respectively then,
 $v_1 = u_1 + 1 (u_1 - u_2) = 2u_1 - u_2 = -14 \text{ m/s}$
 $v_2 = -2 \text{ m/s}$

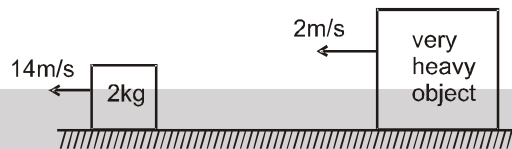

Example 26. A ball is moving with velocity 2 m/s towards a heavy wall moving towards the ball with speed 1 m/s as shown in fig. Assuming collision to be elastic, find the velocity of the ball immediately after the collision.

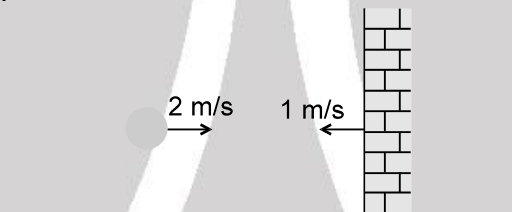

Solution : The speed of wall will not change after the collision. So, let v be the velocity of the ball after collision in the direction shown in figure. Since collision is elastic ($e = 1$),

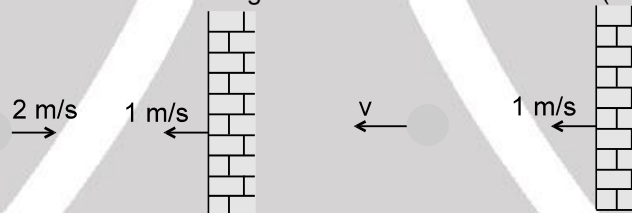

Before Collision
 separation speed = approach speed
 or $v - 1 = 2 + 1$
 or $v = 4 \text{ m/s}$

Ans.

Example 27. Two balls of masses 2 kg and 4 kg are moved towards each other with velocities 4 m/s and 2 m/s respectively on a frictionless surface. After colliding the 2 kg ball returns back with velocity 2 m/s.

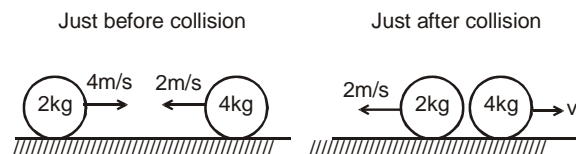

Then find:

- Velocity of 4 kg ball after collision
- Coefficient of restitution e .
- Impulse of deformation J_D .
- Maximum potential energy of deformation.
- Impulse of reformation J_R .



- Solution :**
- (a) By momentum conservation, $2(4) - 4(2) = 2(-2) + 4(v_2) \Rightarrow v_2 = 1 \text{ m/s}$
- (b) $e = \frac{\text{velocity of separation}}{\text{velocity of approach}} = \frac{1 - (-2)}{4 - (-2)} = \frac{3}{6} = 0.5$
- (c) At maximum deformed state, by conservation of momentum, common velocity is $v = 0$.
 $J_D = m_1(v - u_1) = m_2(v - u_2) = 2(0 - 4) = -8 \text{ N-s} = 4(0 - 2) = -8 \text{ N-s}$
 or $= 4(0 - 2) = -8 \text{ N-s}$
- (d) Potential energy at maximum deformed state $U = \text{loss in kinetic energy during deformation}$.
 or $U = \left(\frac{1}{2} m_1 u_1^2 + \frac{1}{2} m_2 u_2^2 \right) - \frac{1}{2} (m_1 + m_2) v^2 = \left(\frac{1}{2} 2(4)^2 + \frac{1}{2} 4(2)^2 \right) - \frac{1}{2} (2 + 4) (0)^2$
 or $U = 24 \text{ Joule}$
- (e) $J_R = m_1(v_1 - v) = m_2(v - v_2) = 2(-2 - 0) = -4 \text{ N-s}$
 or $= 4(0 - 1) = -4 \text{ N-s}$
 or $e = \frac{J_R}{J_D} \Rightarrow J_R = e J_D = (0.5)(-8) = -4 \text{ N-s}$



Collision in two dimension (oblique)

1. A pair of equal and opposite impulses act along common normal direction. Hence, linear momentum of individual particles do change along common normal direction. If mass of the colliding particles remain constant during collision, then we can say that linear velocity of the individual particles change during collision in this direction.
2. No component of impulse act along common tangent direction. Hence, linear momentum or linear velocity of individual particles (if mass is constant) remain unchanged along this direction.
3. Net impulse on both the particles is zero during collision. Hence, net momentum of both the particles remain conserved before and after collision in any direction.
4. Definition of coefficient of restitution can be applied along common normal direction, i.e., along common normal direction we can apply
 Relative speed of separation = e (relative speed of approach)

Solved Example

Example 28. A ball of mass m hits a floor with a speed v_0 making an angle of incidence α with the normal. The coefficient of restitution is e . Find the speed of the reflected ball and the angle of reflection of the ball.

Solution : The component of velocity v_0 along common tangential direction $v_0 \sin \alpha$ will remain unchanged. Let v be the component along common normal direction after collision. Applying, Relative speed of separation = e (Relative speed of approach) along common normal direction, we get $v = e v_0 \cos \alpha$

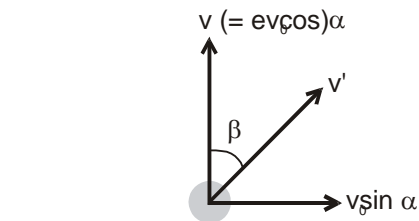
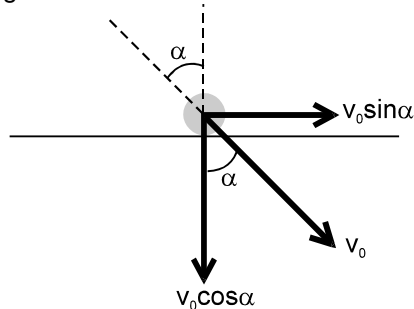



Thus, after collision components of velocity v' are $v_0 \sin \alpha$ and $e v_0 \cos \alpha$

$$\therefore v' = \sqrt{(v_0 \sin \alpha)^2 + (e v_0 \cos \alpha)^2}$$

$$\text{and } \tan \beta = \frac{v_0 \sin \alpha}{e v_0 \cos \alpha} \quad \text{or} \quad \tan \beta = \frac{\tan \alpha}{e}$$

Note : For elastic collision, $e = 1$

$$\therefore v' = v_0 \quad \text{and} \quad \beta = \alpha$$

Ans.

Ans.

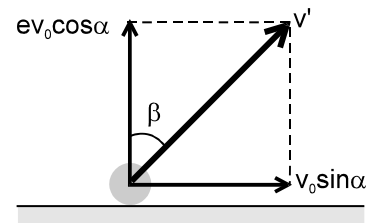

Example 29.

A ball of mass m makes an elastic collision with another identical ball at rest. Show that if the collision is oblique, the bodies go at right angles to each other after collision.

Solution :

In head on elastic collision between two particles, they exchange their velocities. In this case, the component of ball 1 along common normal direction, $v \cos \theta$

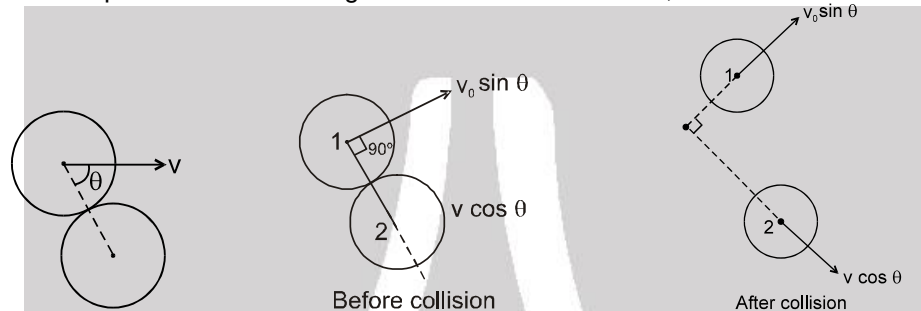

becomes zero after collision, while that of 2 becomes $v \cos \theta$. While the components along common tangent direction of both the particles remain unchanged. Thus, the components along common tangent and common normal direction of both the balls in tabular form are given below.

Ball	Component along common tangent direction		Component along common normal direction	
	Before collision	After collision	Before collision	After collision
1	$v \sin \theta$	$v \sin \theta$	$v \cos \theta$	0
2	0	0	0	$v \cos \theta$

From the above table and figure, we see that both the balls move at right angle after collision with velocities $v \sin \theta$ and $v \cos \theta$.

Note : When two identical bodies have an oblique elastic collision, with one body at rest before collision, then the two bodies will go in \perp directions.

Example 30.

Two spheres are moving towards each other. Both have same radius but their masses are 2 kg and 4 kg. If the velocities are 4 m/s and 2 m/s respectively and coefficient of restitution is $e = 1/3$, find.

- The common velocity along the line of impact.
- Final velocities along line of impact.
- Impulse of deformation.
- impulse of reformation.
- Maximum potential energy of deformation.
- Loss in kinetic energy due to collision.

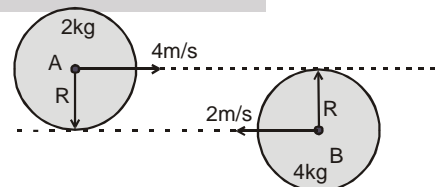



Solution :

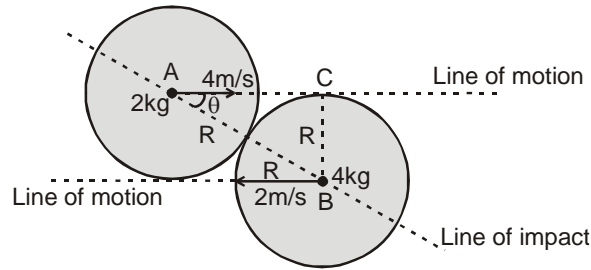

In $\triangle ABC$ $\sin \theta = \frac{BC}{AB} = \frac{R}{2R} = \frac{1}{2}$ or $\theta = 30^\circ$

(a) By conservation of momentum along line of impact.

Just Before Collision Along LOI Maximum Deformed State

$2(4 \cos 30^\circ) - 4(2 \cos 30^\circ) = (2 + 4)v$
 or $v = 0$ (common velocity along LOI)

(b)

Just After Collision Along LOI

Let v_1 and v_2 be the final velocity of A and B respectively then, by conservation of momentum along line of impact,

$2(4 \cos 30^\circ) - 4(2 \cos 30^\circ) = 2(v_1) + 4(v_2)$
 or $0 = v_1 + 2v_2$ (1)

By coefficient of restitution,

$e = \frac{\text{velocity of separation along LOI}}{\text{velocity of approach along LOI}}$

or $\frac{1}{3} = \frac{v_2 - v_1}{4 \cos 30^\circ + 2 \cos 30^\circ}$ or $v_2 - v_1 = \sqrt{3}$ (2)

from the above two equations,

$v_1 = \frac{-2}{\sqrt{3}} \text{ m/s}$ and $v_2 = \frac{1}{\sqrt{3}} \text{ m/s}$

(c) $J_D = m_1(v - u_1) = 2(0 - 4 \cos 30^\circ) = -4\sqrt{3} \text{ N-s}$

(d) $J_R = eJ_D = \frac{1}{3} (-4\sqrt{3}) = -\frac{4}{\sqrt{3}} \text{ N-s}$



- (e) Maximum potential energy of deformation is equal to loss in kinetic energy during deformation upto maximum deformed state,

$$U = \frac{1}{2} m_1 (u_1 \cos \theta)^2 + \frac{1}{2} m_2 (u_2 \cos \theta)^2 - \frac{1}{2} (m_1 + m_2) v^2$$

$$= \frac{1}{2} 2(4 \cos 30^\circ)^2 + \frac{1}{2} 4(-2 \cos 30^\circ)^2 - \frac{1}{2} (2 + 4) (0)^2 \quad \text{or} \quad U = 18 \text{ Joule}$$

- (f) Loss in kinetic energy, $\Delta KE = \frac{1}{2} m_1 (u_1 \cos \theta)^2 + \frac{1}{2} m_2 (u_2 \cos \theta)^2 - \left(\frac{1}{2} m_1 v_1^2 + \frac{1}{2} m_2 v_2^2 \right)$
- $$= \frac{1}{2} 2(4 \cos 30^\circ)^2 + \frac{1}{2} 4(-2 \cos 30^\circ)^2 - \left(\frac{1}{2} 2 \left(\frac{2}{\sqrt{3}} \right)^2 + \frac{1}{2} 4 \left(\frac{1}{\sqrt{3}} \right)^2 \right)$$

$$\Delta KE = 16 \text{ Joule}$$

Example 31. Two point particles A and B are placed in line on a frictionless horizontal plane. If particle A (mass 1 kg) is moved with velocity 10 m/s towards stationary particle B (mass 2 kg) and after collision the two move at an angle of 45° with the initial direction of motion, then find :

- (a) Velocities of A and B just after collision.
 (b) Coefficient of restitution.

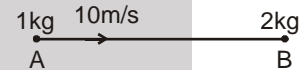

Solution :

The very first step to solve such problems is to find the line of impact which is along the direction of force applied by A on B, resulting the stationary B to move. Thus, by watching the direction of motion of B, line of impact can be determined. In this case line of impact is along the direction of motion of B. i.e. 45° with the initial direction of motion of A.

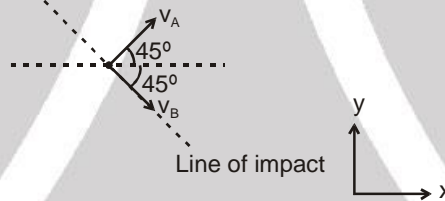

- (a) By conservation of momentum, along x direction: $m_A u_A = m_A v_A \cos 45^\circ + m_B v_B \cos 45^\circ$
 or $1(10) = 1(v_A \cos 45^\circ) + 2(v_B \cos 45^\circ)$

$$\text{or } v_A + 2v_B = 10\sqrt{2} \quad \dots(1)$$

along y direction

$$0 = m_A v_A \sin 45^\circ + m_B v_B \sin 45^\circ$$

$$\text{or } 0 = 1(v_A \sin 45^\circ) - 2(v_B \sin 45^\circ)$$

$$\text{or } v_A = 2v_B \quad \dots(2)$$

solving the two equations,

$$v_A = \frac{10}{\sqrt{2}} \text{ m/s} \quad \text{and} \quad v_B = \frac{5}{\sqrt{2}} \text{ m/s}$$

- (b) $e = \frac{\text{velocity of separation along line of impact}}{\text{velocity of approach along line of impact}}$

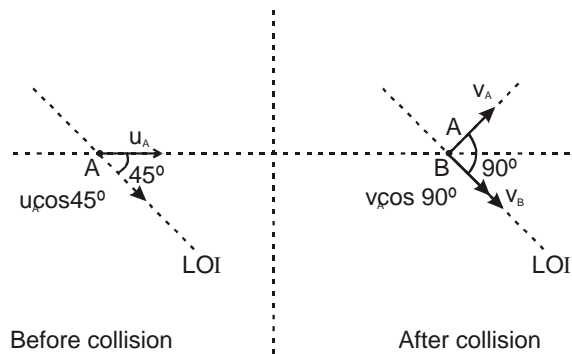

$$\text{or } e = \frac{v_B - v_A \cos 90^\circ}{u_A \cos 45^\circ} = \frac{\frac{5}{\sqrt{2}} - 0}{\frac{10}{\sqrt{2}}} = \frac{1}{2} \quad \text{Ans.}$$

- Example 32.** A smooth sphere of mass m is moving on a horizontal plane with a velocity $3\hat{i} + \hat{j}$ when it collides with a vertical wall which is parallel to the vector \hat{j} . If the coefficient of restitution between the sphere and the wall is $\frac{1}{2}$, find
- the velocity of the sphere after impact,
 - the loss in kinetic energy caused by the impact.
 - the impulse \vec{J} that acts on the sphere.

Solution :

Let \vec{v} be the velocity of the sphere after impact.

To find \vec{v} we must separate the velocity components parallel and perpendicular to the wall.

Using the law of restitution the component of velocity parallel to the wall remains unchanged while component perpendicular to the wall becomes e times in opposite direction.

$$\text{Thus, } \vec{v} = -\frac{3}{2}\hat{i} + \hat{j}$$

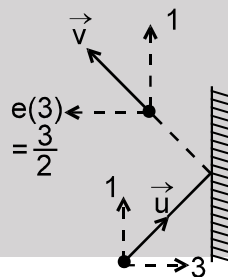

- (a) Therefore, the velocity of the sphere after impact is $-\frac{3}{2}\hat{i} + \hat{j}$ **Ans.**

(b) The loss in K.E. = $\frac{1}{2}mv^2 - \frac{1}{2}mu^2 = \frac{1}{2}m(3^2 + 1^2) - \frac{1}{2}m\left(\left\{\frac{3}{2}\right\}^2 + 1^2\right) = \frac{27}{8}m$ **Ans.**

(c) $\vec{J} = \Delta\vec{P} = \vec{P}_f - \vec{P}_i = m(\vec{v}) - m(\vec{u}) = m\left(-\frac{3}{2}\hat{i} + \hat{j}\right) - m(3\hat{i} + \hat{j}) = -\frac{9}{2}m\hat{i}$ **Ans.**



Example 33. Two smooth spheres, A and B, having equal radii, lie on a horizontal table. A is of mass m and B is of mass $3m$. The spheres are projected towards each other with velocity vector $5\hat{i} + 2\hat{j}$ and $2\hat{i} - \hat{j}$ respectively and when they collide the line joining their centers is parallel to the vector \hat{i} .

If the coefficient of restitution between A and B is $\frac{1}{3}$, find the velocities after impact and the loss in kinetic energy caused by the collision. Find also the magnitude of the impulses that act at the instant of impact.

Solution : The line of centers at impact, is parallel to the vector \hat{i} , the velocity components of A and B perpendicular to \hat{i} are unchanged by the impact.

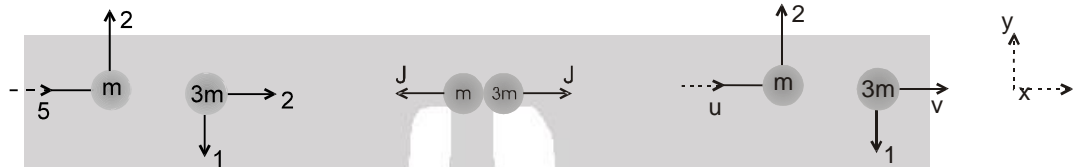

Applying conservation of linear momentum and the law of restitution, we have in x direction $5m + (3m)(2) = mu + 3mv$ (i)

and $\frac{1}{3}(5 - 2) = v - u$ (ii)

Solving these equations, we have $u = 2$ and $v = 3$

The velocities of A and B after impact are therefore,

$$2\hat{i} + 2\hat{j} \text{ and } 3\hat{i} - \hat{j} \text{ respectively}$$

Ans.

Before impact the kinetic energy of A is $\frac{1}{2}m(5^2 + 2^2) = \frac{29}{2}m$

and of B is $\frac{1}{2}(3m)(2^2 + 1^2) = \frac{15}{2}m$

After impact the kinetic energy of A is $\frac{1}{2}m(2^2 + 2^2) = 4m$

and of B is $\frac{1}{2}(3m)(3^2 + 1^2) = 15m$

Therefore, the loss in K.E. at impact is $\frac{29}{2}m + \frac{15}{2}m - 4m - 15m = 3m$

Ans.

To find value of J , we consider the change in momentum along \hat{i} for one sphere only.

For sphere B $J = 3m(3 - 2)$ or $J = 3m$

Ans.

Example 34. A small steel ball A is suspended by an inextensible thread of length $\ell = 1.5$ from O. Another identical ball is thrown vertically downwards such that its surface remains just in contact with thread during downward motion and collides elastically with the suspended ball. If the suspended ball just completes vertical circle after collision, calculate the velocity of the falling ball just before collision. ($g = 10 \text{ ms}^{-2}$)

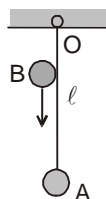



Solution : Velocity of ball A just after collision is $\sqrt{5gl}$

Let radius of each ball be r and the joining centers of the two balls makes an angle θ with the vertical at the instant of collision, then

$$\sin \theta = \frac{r}{2r} = \frac{1}{2} \text{ or } \theta = 30^\circ$$

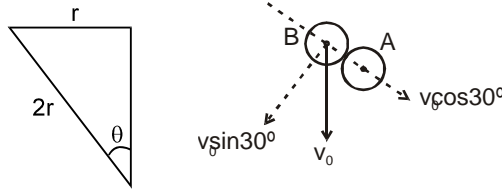

Let velocity of ball B (just before collision) be v_0 . This velocity can be resolved into two components, (i) $v_0 \cos 30^\circ$, along the line joining the center of the two balls and (ii) $v_0 \sin 30^\circ$ normal to this line. Head-on collision takes place due to $v_0 \cos 30^\circ$ and the component $v_0 \sin 30^\circ$ of velocity of ball B remains unchanged.

Since, ball A is suspended by an inextensible string, therefore, just after collision, it can move along horizontal direction only. Hence, a vertically upward impulse is exerted by thread on the ball A. This means that during collision two impulses act on ball A simultaneously. One is impulsive interaction J between the balls and the other is impulsive reaction J' of the thread.

Velocity v_1 of ball B along line of collision is given by

$$J - mv_0 \cos 30^\circ = mv_1$$

$$\text{or } v_1 = \frac{J}{m} - v_0 \cos 30^\circ \quad \dots(i)$$

Horizontal velocity v_2 of ball A is given by $J \sin 30^\circ = mv_2$

$$\text{or } v_2 = \frac{J}{2m} \quad \dots(ii)$$

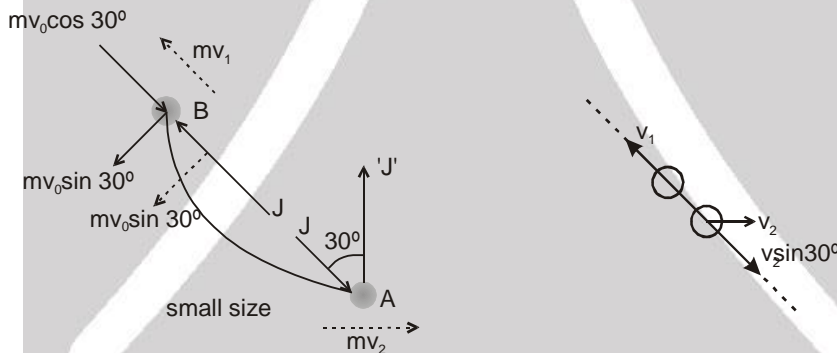

Since, the balls collide elastically, therefore, coefficient of restitution is $e = 1$.

$$\text{Hence, } e = \frac{v_2 \sin 30^\circ - (-v_1)}{v_0 \cos 30^\circ - 0} = 1 \quad \dots(iii)$$

Solving Eqs. (i), (ii), and (iii), $J = 1.6 mv_0 \cos 30^\circ$

$$\therefore v_1 = 0.6 v_0 \cos 30^\circ \text{ and } v_2 = 0.8 v_0 \cos 30^\circ$$

Since, ball A just completes vertical circle, therefore $v_2 = \sqrt{5gl}$

$$\therefore 0.8v_0 \cos 30^\circ = \sqrt{5gl} \text{ or } v_0 = 12.5 \text{ ms}^{-1} \quad \text{Ans.}$$



VARIABLE MASS SYSTEM :

If a mass is added or ejected from a system, at rate μ kg/s and relative velocity \vec{v}_{rel} (w.r.t. the system), then the force exerted by this mass on the system has magnitude $\mu|\vec{v}_{rel}|$.

Thrust Force (\vec{F}_t)

$$\vec{F}_t = \vec{v}_{rel} \left(\frac{dm}{dt} \right)$$



Suppose at some moment $t = t$ mass of a body is m and its velocity is \vec{v} . After some time at $t = t + dt$ its mass becomes $(m - dm)$ and velocity becomes $\vec{v} + d\vec{v}$. The mass dm is ejected with relative velocity \vec{v}_r . Absolute velocity of mass 'dm' is therefore $(\vec{v} + \vec{v}_r)$. If no external forces are acting on the system, the linear momentum of the system will remain conserved, or $\vec{P}_i = \vec{P}_f$

$$\text{or } m\vec{v} = (m - dm)(\vec{v} + d\vec{v}) + dm(\vec{v} + \vec{v}_r)$$

$$\text{or } m\vec{v} = m\vec{v} + md\vec{v} - (dm)\vec{v} - (dm)(d\vec{v}) + (dm)\vec{v} + \vec{v}_r dm$$

The term $(dm)(d\vec{v})$ is too small and can be neglected.

$$\therefore md\vec{v} = -\vec{v}_r dm \text{ or } m\left(\frac{d\vec{v}}{dt}\right) = \vec{v}_r\left(-\frac{dm}{dt}\right)$$

$$\text{Here, } m\left(-\frac{d\vec{v}}{dt}\right) = \text{thrust force } (\vec{F}_t)$$

$$\text{and } -\frac{dm}{dt} = \text{rate at which mass is ejecting}$$

$$\text{or } \vec{F}_t = \vec{v}_r\left(\frac{dm}{dt}\right)$$

Problems related to variable mass can be solved in following four steps

1. Make a list of all the forces acting on the main mass and apply them on it.
2. Apply an additional thrust force \vec{F}_t on the mass, the magnitude of which is $\left|\vec{v}_r\left(\pm\frac{dm}{dt}\right)\right|$ and direction is given by the direction of \vec{v}_r in case the mass is increasing and otherwise the direction of $-\vec{v}_r$ if it is decreasing.
3. Find net force on the mass and apply $\vec{F}_{\text{net}} = m\frac{d\vec{v}}{dt}$ (m = mass at the particular instant)
4. Integrate it with proper limits to find velocity at any time t .

Note : Problems of one-dimensional motion (which are mostly asked in JEE) can be solved in easier manner just by assigning positive and negative signs to all vector quantities. Here are few example in support of the above theory.

Solved Examples

Example 35. A flat car of mass m_0 starts moving to the right due to a constant horizontal force F . Sand spills on the flat car from a stationary hopper. The rate of loading is constant and equal to μ kg/s. Find the time dependence of the velocity and the acceleration of the flat car in the process of loading. The friction is negligibly small.

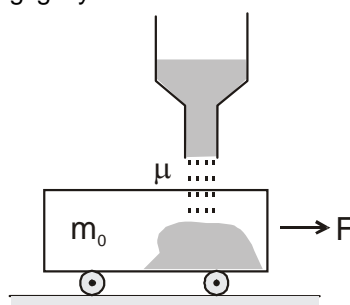



Solution : Initial velocity of the flat car is zero. Let v be its velocity at time t and m its mass at that instant. Then

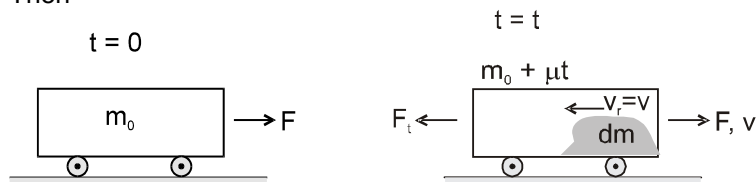

At $t = 0$, $v = 0$ and $m = m_0$ at $t = t$, $v = v$ and $m = m_0 + \mu t$
Here, $v_r = v$ (backwards)

$$\frac{dm}{dt} = \mu$$

$$\therefore F_t = v_r \frac{dm}{dt} = \mu v \quad (\text{backwards})$$

Net force on the flat car at time t is $F_{\text{net}} = F - F_t$

$$\text{or } m \frac{dv}{dt} = F - \mu v \quad \dots(i)$$

$$\text{or } (m_0 + \mu t) \frac{dv}{dt} = F - \mu v$$

$$\text{or } \int_0^v \frac{dv}{F - \mu v} = \int_0^t \frac{dt}{m_0 + \mu t}$$

$$\therefore -\frac{1}{\mu} [\ln(F - \mu v)]_0^v = \frac{1}{\mu} [\ln(m_0 + \mu t)]_0^t$$

$$\Rightarrow \ln\left(\frac{F}{F - \mu v}\right) = \ln\left(\frac{m_0 + \mu t}{m_0}\right)$$

$$\therefore \frac{F}{F - \mu v} = \frac{m_0 + \mu t}{m_0} \quad \text{or} \quad v = \frac{Ft}{m_0 + \mu t} \quad \text{Ans.}$$

From Eq. (i), $\frac{dv}{dt} = \text{acceleration of flat car at time } t$

$$\text{or } = \frac{F - \mu v}{m}$$

$$a = \left(\frac{F - \frac{F\mu t}{m_0 + \mu t}}{m_0 + \mu t} \right) \quad \text{or} \quad a = \frac{Fm_0}{(m_0 + \mu t)^2} \quad \text{Ans.}$$

Example 36. A cart loaded with sand moves along a horizontal floor due to a constant force F coinciding in direction with the cart's velocity vector. In the process sand spills through a hole in the bottom with a constant rate $\mu \text{ kg/s}$. Find the acceleration and velocity of the cart at the moment t , if at the initial moment $t = 0$ the cart with loaded sand had the mass m_0 and its velocity was equal to zero. Friction is to be neglected.

Solution : In this problem the sand spills through a hole in the bottom of the cart. Hence, the relative velocity of the sand v_r will be zero because it will acquire the same velocity as that of the cart at the moment.

$$v_r = 0$$

$$\text{Thus, } F_t = 0 \quad \left(\text{as } F_t = v_r \frac{dm}{dt} \right)$$

and the net force will be F only.

$$\therefore F_{\text{net}} = F$$

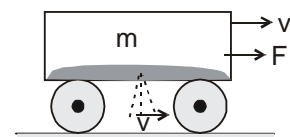



$$\text{or } m \left(\frac{dv}{dt} \right) = F \quad \dots(i)$$

But here $m = m_0 - \mu t$

$$\therefore (m_0 - \mu t) \frac{dv}{dt} = F \quad \text{or} \quad \int_0^v dv = \int_0^t \frac{F}{m_0 - \mu t} dt$$

$$\therefore v = \frac{F}{-\mu} \left[\ln(m_0 - \mu t) \right]_0^t \quad \text{or} \quad v = \frac{F}{\mu} \ln \left(\frac{m_0}{m_0 - \mu t} \right) \quad \text{Ans.}$$

From eq. (i), acceleration of the cart

$$a = \frac{dv}{dt} = \frac{F}{m} \quad \text{or} \quad a = \frac{F}{m_0 - \mu t} \quad \text{Ans.}$$



Rocket propulsion :

Let m_0 be the mass of the rocket at time $t = 0$. m its mass at any time t and v its velocity at that moment. Initially, let us suppose that the velocity of the rocket is u .

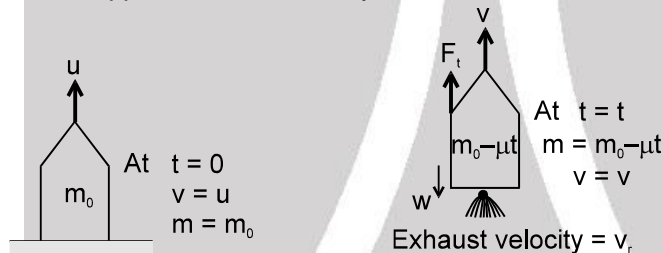

Further, let $\left(\frac{-dm}{dt} \right)$ be the mass of the gas ejected per unit time and v_r the exhaust velocity of the gases with respect to rocket. Usually $\left(\frac{-dm}{dt} \right)$ and v_r are kept constant throughout the journey of the rocket. Now, let us write few equations which can be used in the problems of rocket propulsion. At time $t = t$,

1. Thrust force on the rocket $F_t = v_r \left(\frac{-dm}{dt} \right)$ (upwards)
2. Weight of the rocket $W = mg$ (downwards)
3. Net force on the rocket $F_{\text{net}} = F_t - W$ (upwards)

$$\text{or } F_{\text{net}} = v_r \left(\frac{-dm}{dt} \right) - mg$$

4. Net acceleration of the rocket $a = \frac{F}{m}$

$$\text{or } \frac{dv}{dt} = \frac{v_r}{m} \left(\frac{-dm}{dt} \right) - g$$

$$\text{or } dv = \frac{v_r}{m} (-dm) - g dt$$

$$\text{or } \int_u^v dv = v_r \int_{m_0}^m \frac{-dm}{m} - g \int_0^t dt$$

$$\text{Thus, } v = u - gt + v_r \ln \left(\frac{m_0}{m} \right) \quad \dots(i)$$



Note :

1. $F_t = v_r \left(-\frac{dm}{dt} \right)$ is upwards, as v_r is downwards and $\frac{dm}{dt}$ is negative.
2. If gravity is ignored and initial velocity of the rocket $u = 0$, Eq. (i) reduces to $v = v_r \ln \left(\frac{m_0}{m} \right)$

Solved Examples

Example 37. A rocket, with an initial mass of 1000 kg, is launched vertically upwards from rest under gravity. The rocket burns fuel at the rate of 10 kg per second. The burnt matter is ejected vertically downwards with a speed of 2000 ms^{-1} relative to the rocket. If burning stops after one minute. Find the maximum velocity of the rocket. (Take g as at 10 ms^{-2})

Solution : Using the velocity equation $v = u - gt + v_r \ln \left(\frac{m_0}{m} \right)$
 Here $u = 0$, $t = 60\text{s}$, $g = 10 \text{ m/s}^2$, $v_r = 2000 \text{ m/s}$, $m_0 = 1000 \text{ kg}$
 and $m = 1000 - 10 \times 60 = 400 \text{ kg}$
 We get $v = 0 - 600 + 2000 \ln \left(\frac{1000}{400} \right)$
 or $v = 2000 \ln 2.5 - 600$
 The maximum velocity of the rocket is $200(10 \ln 2.5 - 3) = 1232.6 \text{ ms}^{-1}$ **Ans.**



LINEAR MOMENTUM CONSERVATION IN PRESENCE OF EXTERNAL FORCE.

$$\vec{F}_{\text{ext}} = \frac{d\vec{P}}{dt} \Rightarrow \vec{F}_{\text{ext}} dt = d\vec{P} \Rightarrow d\vec{P} = \vec{F}_{\text{ext}} \text{)impulsive } dt$$

$$\therefore \text{ If } \vec{F}_{\text{ext}} \text{)impulsive} = 0 \Rightarrow d\vec{P} = 0$$

or \vec{P} is constant

Note : Momentum is conserved if the external force present is non-impulsive. eg. gravitation or spring force.

Solved Examples

Example 38. Two balls are moving towards each other on a vertical line collides with each other as shown. Find their velocities just after collision.



Solution : Let the final velocity of 4 kg ball just after collision be v . Since, external force is gravitational which is non - impulsive, hence, linear momentum will be conserved.
 Applying linear momentum conservation :

$$2(-3) + 4(4) = 2(4) + 4(v) \quad \text{or} \quad v = \frac{1}{2} \text{ m/s}$$





Example 39. A bullet of mass 50g is fired from below into the bob of mass 450g of a long simple pendulum as shown in figure. The bullet remains inside the bob and the bob rises through a height of 1.8 m. Find the speed of the bullet. Take $g = 10 \text{ m/s}^2$.

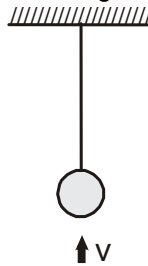

Solution : Let the speed of the bullet be v . Let the common velocity of the bullet and the bob, after the bullet is embedded into the bob, is V . By the principle of conservation of the linear momentum,

$$V = \frac{(0.05 \text{ kg}) v}{0.45 \text{ kg} + 0.05 \text{ kg}} = \frac{v}{10}$$

The string becomes loose and the bob will go up with a deceleration of $g = 10 \text{ m/s}^2$. As it comes to rest at a height of 1.8 m, using the equation $v^2 = u^2 + 2ax$,

$$1.8 \text{ m} = \frac{(v/10)^2}{2 \times 10 \text{ m/s}^2} \quad \text{or,} \quad v = 60 \text{ m/s.}$$

Example 40. A small ball of mass m collides with a rough wall having coefficient of friction μ at an angle θ with the normal to the wall. If after collision the ball moves with angle α with the normal to the wall and the coefficient of restitution is e then find the reflected velocity v of the ball just after collision.

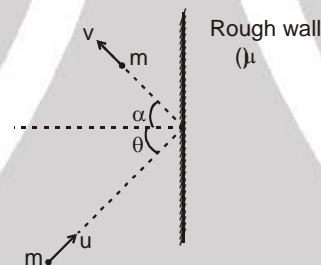

Solution : $mv \cos \alpha - (m(-u \cos \theta)) = \int N dt$

$$mv \sin \alpha - mu \sin \theta = -\mu \int N dt$$

$$\text{and } e = \frac{v \cos \alpha}{u \cos \theta} \quad \Rightarrow \quad v \cos \alpha = eu \cos \theta$$

$$\text{or } mv \sin \alpha - mu \sin \theta = -\mu(mv \cos \alpha + mu \cos \theta)$$

$$\text{or } v = \frac{u}{\sin \alpha} [\sin \theta - \mu \cos \theta (e + 1)] \quad \text{Ans.}$$

Solved Miscellaneous Problems

Problem 1. Three particles of masses 0.5 kg, 1.0 kg and 1.5 kg are placed at the three corners of a right angled triangle of sides 3.0 cm, 4.0 cm and 5.0 cm as shown in figure. Locate the center of mass of the system.

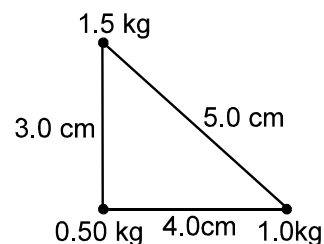



Solution :

taking x and y axes as shown.

coordinates of body A = (0,0)

coordinates of body B = (4,0)

coordinates of body C = (0,3)

$$x\text{-coordinate of c.m.} = \frac{m_A x_A + m_B x_B + m_C x_C}{m_A + m_B + m_C}$$

$$= \frac{0.5 \times 0 + 1.0 \times 4 + 1.5 \times 0}{0.5 + 1.0 + 1.5} = \frac{4 \text{ kg-cm}}{3 \text{ kg}} = 1.33 \text{ cm}$$

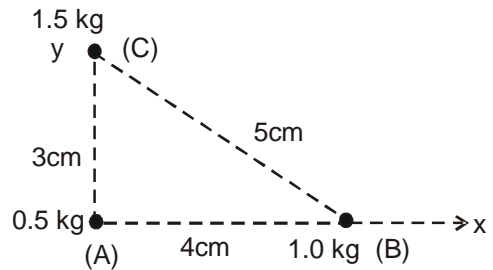

$$\text{similarly y - coordinate of c.m.} = \frac{0.5 \times 0 + 1.0 \times 0 + 1.5 \times 3}{0.5 + 1.0 + 1.5} = \frac{4.5 \text{ kg-cm}}{3 \text{ kg}} = 1.5 \text{ cm}$$

So, center of mass is 1.33 cm right and 1.5 cm above particle A.

Problem 2.

The linear mass density of a straight rod of length L varies as $\rho = A + Bx$ where x is the distance from the left end. Locate the center of mass from left end.

Solution :

Let take a strip of width 'dx' at distance x from one end.

dm = mass of 'dx' strip = ρdx

$$dm = (A+Bx)dx \quad \dots\dots(1)$$

$$\text{By definition } X_{\text{com}} = \frac{\int_0^L x dm}{\int_0^L dm}$$

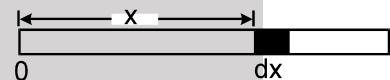

$$\text{from eq (1)} \Rightarrow X_{\text{com}} = \frac{\int_0^L x(A+Bx)dx}{\int_0^L (A+Bx)dx} = \frac{\int_0^L (Ax+Bx^2)dx}{\int_0^L (A+Bx)dx} = \frac{\frac{AL^2}{2} + \frac{BL^3}{3}}{AL + \frac{BL^2}{2}} = \frac{3AL + 2BL^2}{3(2A + BL)}$$

Ans.

Problem 3.

Half of the rectangular plate shown in figure is made of a material of density ρ_1 and the other half of density ρ_2 . The length of the plate is L. Locate the center of mass of the plate.

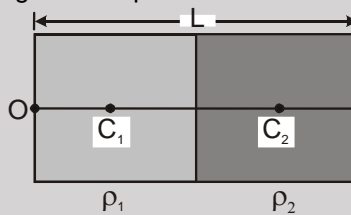

Solution :

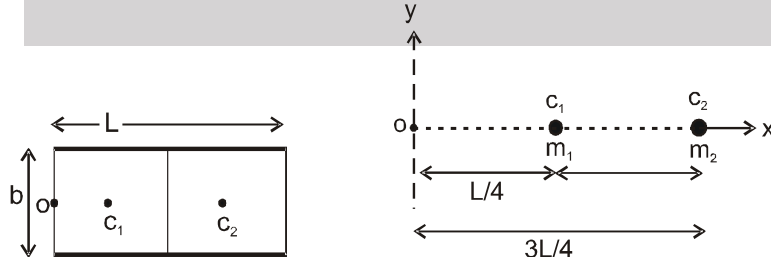

Replacing half of rectangular plate by a point mass at its center of mass as shown in figure.

$$M_1 = \frac{\rho_1 L}{2} b \quad M_2 = \frac{\rho_2 L}{2} b$$

$$X_{\text{com}} = \frac{m_1 \frac{L}{4} + m_2 \frac{3L}{4}}{m_1 + m_2} = \frac{\left(\rho_1 \cdot \frac{L}{2} \cdot b\right) \frac{L}{4} + \left(\rho_2 \cdot \frac{L}{2} \cdot b\right) \cdot \frac{3L}{4}}{\left(\rho_1 \cdot \frac{L}{2} \cdot b\right) + \left(\rho_2 \cdot \frac{L}{2} \cdot b\right)} = \frac{(\rho_1 + 3\rho_2)}{4(\rho_1 + \rho_2)} L \text{ from point O.}$$



Problem 4. In a boat of mass $4M$ and length ℓ on a frictionless water surface. Two men A (mass = M) and B (mass $2M$) are standing on the two opposite ends. Now A travels a distance $\ell/4$ relative to boat towards its center and B moves a distance $3\ell/4$ relative to boat and meet A. Find the distance travelled by the boat on water till A and B meet.

Solution : Let x is distance travelled by boat.

Initial position of center of mass

$$= \frac{M_{\text{Boat}} X_{\text{Boat}} + M_A X_A + M_B X_B}{M_{\text{Boat}} + M_A + M_B} = \frac{4M \frac{\ell}{2} + M \cdot 0 + 2M \cdot \ell}{4M + M + 2M} = \frac{4M\ell}{7M} = \frac{4}{7} \ell$$

$$\text{Final position of center of mass} = \frac{4M \left\{ \frac{\ell}{2} + x \right\} + M \left\{ x + \frac{\ell}{4} \right\} + 2M \left\{ x + \frac{\ell}{4} \right\}}{7M}$$

$$= \frac{2M\ell + \frac{M\ell}{4} + \frac{M\ell}{2} + 7Mx}{7M} = \frac{\frac{11M\ell}{4} + 7Mx}{7M} = \frac{\frac{11M\ell}{4} + 7x}{7}$$

since there is no horizontal force, position of center of mass remains unchanged.
center of mass initially = center of mass finally

$$\Rightarrow \frac{4}{7} \ell = \frac{\frac{11\ell}{4} + 7x}{7}$$

$$4\ell = \frac{11\ell}{4} + 7x \Rightarrow x = \frac{5\ell}{28}$$

Problem 5. A block A (mass = $4M$) is placed on the top of a wedge B of base length ℓ (mass = $20M$) as shown in figure. When the system is released from rest. Find the distance moved by the wedge B till the block A reaches at lowest end of wedge. Assume all surfaces are frictionless.

Solution : Initial position of center of mass

$$= \frac{X_B M_B + X_A M_A}{M_B + M_A} = \frac{X_B \cdot 20M + \ell \cdot 4M}{24M} = \frac{5X_B + \ell}{6}$$

$$\text{Final position of center of mass} = \frac{(X_B + x)20M + 4Mx}{24M} = \frac{5(X_B + x) + x}{6}$$

since there is no horizontal force on system
center of mass initially = center of mass finally.

$$5X_B + \ell = 5X_B + 5x + x$$

$$\ell = 6x$$

$$x = \frac{\ell}{6}$$

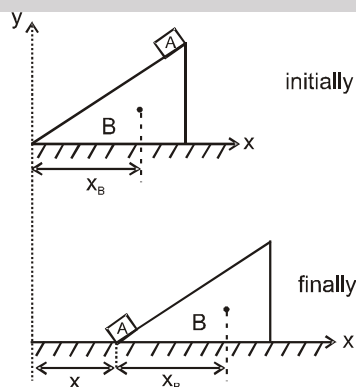



Problem 6. An isolated particle of mass m is moving in a horizontal xy plane, along x -axis. At a certain height above ground, it suddenly explodes into two fragments of masses $m/4$ and $3m/4$. An instant later, the smaller fragment is at $y = +15$ cm. Find the position of heavier fragment at this instant.

Solution : As particle is moving along x -axis, so, y -coordinate of COM is zero.

$$Y_M M = Y_{\frac{M}{4}} \left(\frac{M}{4} \right) + Y_{\frac{3M}{4}} \left(\frac{3M}{4} \right) \Rightarrow 0 \times M = 15 \left(\frac{M}{4} \right) + Y_{\frac{3M}{4}} \left(\frac{3M}{4} \right)$$

$$\boxed{\frac{Y_{3M}}{4} = -5 \text{ cm}}$$

Problem 7. A shell is fired from a cannon with a speed of 100 m/s at an angle 30° with the vertical (y -direction). At the highest point of its trajectory, the shell explodes into two fragments of masses in the ratio 1 : 2. The lighter fragment moves vertically upwards with an initial speed of 200 m/s. What is the speed of the heavier fragment at the time of explosion.

Solution : Velocity at highest point = $u \cos \theta = 100 \cos 60 = 50 \text{ m/s}$.
taking, x and y axes as shown in figure,

Velocity of $m = 50 \hat{i}$ m / sec

m explodes into $\frac{m}{3}$ and $\frac{2m}{3}$, velocity of $\frac{m}{3} = 200 \hat{j}$ m/sec

Let, velocity of $\frac{2m}{3} = \vec{V}$

Applying law of conservation of momentum

$$m \times 50 \hat{i} = \frac{m}{3} \times 200 \hat{j} + \frac{2m}{3} \vec{V} \Rightarrow 50 \hat{i} - \frac{200}{3} \hat{j} = \frac{2}{3} \vec{V}$$

$$\text{so } \vec{V} = 75 \hat{i} - 100 \hat{j}$$

$$\text{Speed} = |\vec{V}| = \sqrt{(75)^2 + (100)^2} = 25 \sqrt{9+16} = 125 \text{ m/sec Ans.}$$

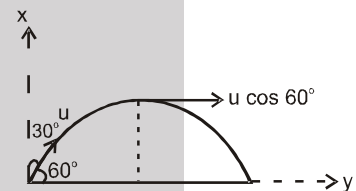

Problem 8. A shell at rest at origin explodes into three fragments of masses 1 kg, 2 kg and m kg. The fragments of masses 1 kg and 2 kg fly off with speeds 12 m/s along x -axis and 8 m/s along y -axis respectively. If m kg flies off with speed 40 m/s then find the total mass of the shell.

Solution : As initial velocity $\vec{V} = 0$, Initial momentum
 $= (1 + 2 + m) \times 0 = 0$

Finally, let velocity of $M = \vec{V}$. We know $|\vec{V}| = 40$ m/s.
Initial momentum = final momentum.

$$0 = 1 \times 12 \hat{i} + 2 \times 8 \hat{j} + m \vec{V}$$

$$\Rightarrow \vec{V} = -\frac{(12\hat{i} + 16\hat{j})}{m}$$

$$|\vec{V}| = \frac{\sqrt{(12)^2 + (16)^2}}{m} = \frac{1}{m} \sqrt{(12)^2 + (16)^2} = 40 \text{ (given)}$$

$$m = \frac{\sqrt{(12)^2 + (16)^2}}{40} = 0.5 \text{ kg}$$

$$\text{Total mass} = 1 + 2 + 0.5 = 3.5 \text{ kg}$$

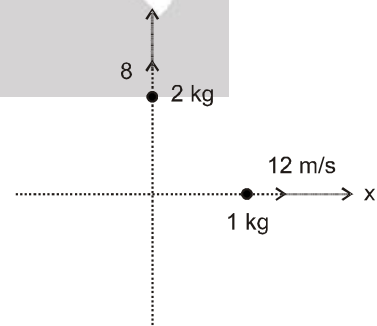

**Problem 9.**

A nucleus (mass no. 238) initially at rest decay into another nucleus (mass no 234) emitting an α particle (mass no - 4) with the speed of 1.17×10^7 m/sec. Find the recoil speed of the remaining nucleus.
[AMT. Sir HCV_Modified] [HCV - I]

Ans. 2.0×10^5 m/s

Sol. $238 \times 0 = 4 \times 1.17 \times 10^7 + 234 \times v_2$
 $V_2 = -2 \times 10^5$ m/sec

Problem 10. A block at rest explodes into three equal parts. Two parts starts moving along X and Y axes respectively with equal speeds of 10 m/s. Find the initial velocity of the third part.

Solution : Let total mass = 3 m, initial linear momentum = $3m \times 0$

Let velocity of third part = \vec{V}

Using conservation of linear momentum :

$$m \times 10 \hat{i} + m \times 10 \hat{j} + m \vec{V} = 0$$

$$\text{So, } \vec{V} = (-10 \hat{i} - 10 \hat{j}) \text{ m/sec.}$$

$$|\vec{V}| = \sqrt{(10)^2 + (10)^2} = 10\sqrt{2}, \text{ making angle } 135^\circ \text{ below x-axis}$$

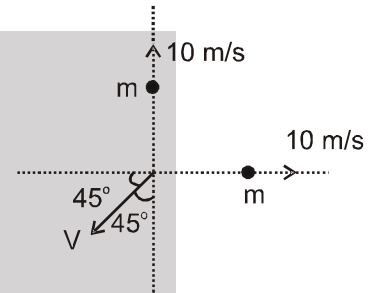

Problem 11. Two persons A and B, each of mass m are standing at the two ends of rail-road car of mass M. The person A jumps to the left with a horizontal speed u with respect to the car. Thereafter, the person B jumps to the right, again with the same horizontal speed u with respect to the car. Find the velocity of the car after both the persons have jumped off.

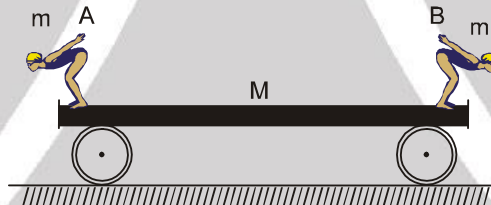

Solution : When person A jumps, let car achieve velocity V in forward direction. So, velocity of 'A' w.r.t. ground = $(u - v)$ in backward direction.

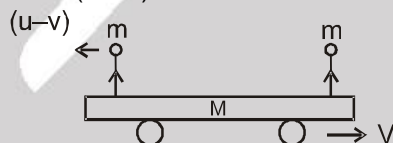

Applying momentum conservation.

$$(M + m)v - m(u - v) = 0$$

$$(M + m)v + mv = mu$$

$$V = \frac{m}{M + 2m} u$$

When person B jumps, let velocity of car becomes V' in forward direction.

So velocity of 'B' w.r.t ground = $u + v'$

Applying momentum conservation :

$$(m + M)V = MV' + m(u + V')$$

$$\frac{(m + M) mu}{M + 2m} = (m + M)V' + mu$$

$$V' = \frac{-m^2 u}{(M + m)(M + 2m)}$$

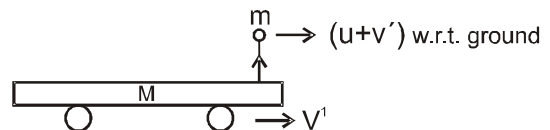



$$V' = \frac{-m^2 u}{(M+m)(M+2m)} \text{ 'backward' } \{-\text{ve sign signifies direction}\}$$

$$= \frac{m^2 u}{(M+2m)(M+m)} \text{ Ans.}$$

Problem 12. Blocks A and B have masses 40 kg and 60 kg respectively. They are placed on a smooth surface and the spring connected between them is stretched by 1.5m. If they are released from rest, determine the speeds of both blocks at the instant the spring becomes unstretched.

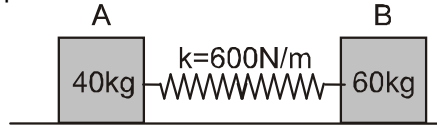

Solution :



Let, both block start moving with velocity V_1 and V_2 as shown in figure
Since no horizontal force on system so, applying momentum conservation

$$0 = 40 V_1 - 60 V_2 \quad \boxed{2V_1 = 3V_2} \quad \text{.....(1)}$$

Now applying energy conservation, Loss in potential energy = gain in kinetic energy

$$\frac{1}{2} kx^2 = \frac{1}{2} m_1 V_1^2 + \frac{1}{2} m_2 V_2^2$$

$$\frac{1}{2} \times 600 \times (1.5)^2 = \frac{1}{2} \times 40 \times V_1^2 + \frac{1}{2} \times 60 \times V_2^2 \quad \text{.....(2)}$$

Solving equation (1) and (2) we get,

$$V_1 = 4.5 \text{ m/s, } V_2 = 3 \text{ m/s.}$$

Problem 13. A block of mass 1.2 kg moving at a speed of 20 cm/s collides head-on with a similar block kept at rest. The coefficient of restitution is 3/5. Find the loss of the kinetic energy during the collision

Solution :

Before collision :



After collision : let final velocity of 'A' and 'B' be u and V respectively

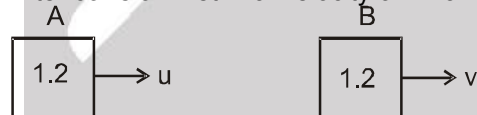

Applying momentum conservation :

$$1.2 \times 0.2 = 1.2 u + 1.2 V$$

$$0.24 = 1.2 (u + V) \quad \text{.....(1)}$$

Coefficient of restitution

$$e = \frac{V - u}{0.2} = \frac{3}{5} \quad \text{.....(2)}$$

Applying momentum conservation :

$$1.24 + 1.2 V = 0.2u \quad u + V = 0.2 \text{ m/s} \quad \text{.....(2)}$$

Solving equation (1) and (2) we have ,

$$V = \frac{4}{25} \text{ m/sec} \quad \text{and} \quad u = \frac{1}{25} \text{ m/sec}$$

Loss of kinetic energy = (initial kinetic energy) – (final kinetic energy)



$$= \frac{1}{2} \times 1.2 \times (0.2)^2 - \left\{ \frac{1}{2} \times 1.2 \times \left(\frac{4}{25}\right)^2 + \frac{1}{2} \times (1.2) \times \left(\frac{1}{25}\right)^2 \right\}$$

$$= 0.6 \left\{ 0.04 - \frac{16}{625} - \frac{1}{625} \right\} = 0.6 \{0.04 \times 0.0256 \times 0.0016\}$$

$$= 0.6 \{0.0128\} = 0.00768 \text{ J} = 7.7 \times 10^{-3} \text{ J}$$

Problem 14. The sphere of mass m_1 travels with an initial velocity u_1 directed as shown and strikes the stationary sphere of mass m_2 head on. For a given coefficient of restitution e , what condition on the mass ratio $\frac{m_1}{m_2}$

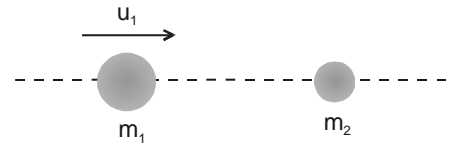

ensures that the final velocity of m_2 is greater than u_1 ?

Solution : Let velocity of m_1 & m_2 after collision be u & V respectively.

$$\text{Coefficient of restitution} = e = \frac{\text{velocity of separation}}{\text{velocity of approach}} = \frac{V - u}{u_1} \dots\dots\dots(1)$$

applying momentum conservation,
initial momentum = final momentum

$$m_1 u_1 = m_1 u + m_2 V \dots\dots\dots(2)$$

$$m_1 u_1 = m_1 (V - eu_1) + m_2 V$$

$$\frac{V}{u_1} = \frac{m_1(1+e)}{m_1+m_2} = \frac{(1+e)}{1+\frac{m_2}{m_1}}$$

$$\frac{(1+e)}{1+\frac{m_2}{m_1}} = \frac{V}{u_1} > 1 \text{ \{given\}}$$

$$\boxed{\frac{m_1}{m_2} > \frac{1}{e}} \text{ Ans.}$$

Problem 15. Find the mass of the rocket as a function of time, if it moves with a constant acceleration a , in absence of external forces. The gas escapes with a constant velocity u relative to the rocket and its initial mass was m_0 .

Solution : Using, $F_{\text{net}} = V_{\text{rel}} \left(\frac{-dm}{dt} \right)$

$$F_{\text{net}} = -u \frac{dm}{dt} \dots\dots(1)$$

$$F_{\text{net}} = ma \dots\dots(2)$$

Solving equation (1) and (2)

$$ma = -u \frac{dm}{dt}$$

$$\int_{m_0}^m \frac{dm}{m} = \int_0^t \frac{-adt}{u} \quad \ln \frac{m}{m_0} = \frac{-at}{u}$$

$$\frac{m}{m_0} = e^{-at/u}$$

$$\boxed{m = m_0 e^{-\frac{at}{u}}} \text{ Ans.}$$

Problem 16. If the chain is lowered at a constant speed $v = 1.2 \text{ m/s}$, determine the normal reaction exerted on the floor as a function of time. The chain has a mass of 80 kg and a total length of 6 m .

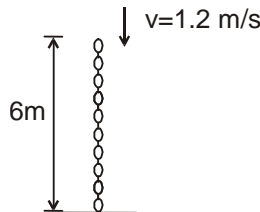



Solution : after time 't'

$$\text{Linear mass density of chain} = \frac{80}{6} = \frac{40}{3} \text{ kg/m} = \lambda$$

$$\begin{aligned} \text{Weight of portion of chain lying on ground} &= mg \\ &= \frac{40}{3} \times 1.2 t \times \frac{40}{3} \times 1.2 t = 16 t, \text{ N} \end{aligned}$$

$$\text{Thrust force} = F_t = V \times \frac{dm}{dt}$$

$$= 1.2 \times \lambda v = 1.2 \lambda v = 1.2 \times \frac{40}{3} \times 1.2 = 1.2 \times 40 \times 0.4 = 19.2 \text{ N}$$

Normal reaction exerted on floor = $W + F_t = (16t + 19.2)$ N vertically downward

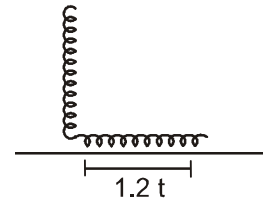

Problem 17. A ball is approaching to ground with speed u . If the coefficient of restitution is e then find out:



- (a) the velocity just after collision.
 (b) the impulse exerted by the normal due to ground on the ball.

Solution :

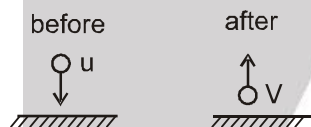

$$e = \frac{\text{velocity of separation}}{\text{velocity of approach}} = \frac{v}{u}$$

- (a) velocity after collision = $V = eu$ (1)
 (b) Impulse exerted by the normal due to ground on the ball = change in momentum of ball.
 $= \{\text{final momentum}\} - \{\text{initial momentum}\}$
 $= \{m v\} - \{-m u\} = m v + m u$
 $= m \{u + eu\}$
 $= m u \{1 + e\}$ **Ans.**

Problem 18.

Comprehension :

A small block of mass M moves on a frictionless surface of an inclined plane, as shown in figure. The angle of the incline suddenly changes from 60° to 30° at point B. The block is initially at rest at A. Assume that collisions between the block and the incline are totally inelastic ($g = 10 \text{ m/s}^2$)

Figure :

[JEE-2008, 12/163]

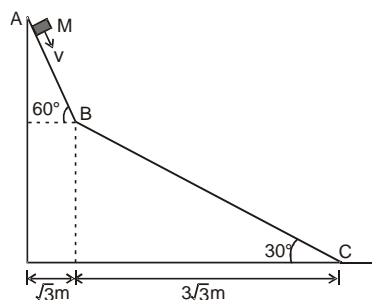



1. The speed of the block at point B immediately after it strikes the second incline is
 (A) $\sqrt{60}$ m/s (B*) $\sqrt{45}$ m/s (C) $\sqrt{30}$ m/s (D) $\sqrt{15}$ m/s

Sol. At point B there is perfectly inelastic collision so component of velocity \perp to incline plane becomes zero and component parallel to second surface is retained

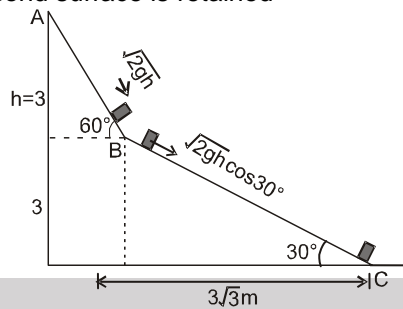

velocity immediately after it strikes second incline

$$V = \sqrt{2gh} \cos 30^\circ = \sqrt{2 \times 10 \times 3} \times \frac{\sqrt{3}}{2} = \sqrt{\frac{2 \times 10 \times 9}{4}}$$

$$V = \sqrt{45} \text{ m/s}$$

2. The speed of the block at point C, immediately before it leaves the second incline is
 (A) $\sqrt{120}$ m/s (B*) $\sqrt{105}$ m/s (C) $\sqrt{90}$ m/s (D) $\sqrt{75}$ m/s

Sol. At point 'C'

$$V_C^2 = V_B^2 + 2gh$$

$$V_C^2 = 45 + 2 \times 10 \times 3$$

$$V_C = \sqrt{105} \text{ m/s Ans. (B)}$$

3. If collision between the block and the incline is completely elastic, then the vertical (upward) component of the velocity of the block at point B, immediately after it strikes the second incline is
 (A) $\sqrt{30}$ m/s (B) $\sqrt{15}$ m/s (C*) 0 (D) $-\sqrt{15}$ m/s

Sol. The block coming down from incline AB makes an angle 30° with incline BC. If the block collides with incline BC elastically, the angle of block after collision with the incline shall be 30° . Hence just after collision with incline BC the velocity of block shall be horizontal. So immediately after the block strikes second inclined, its vertical component of velocity will be zero.